

SII ●

LTPD245A/B, LTPD345A/B  
THERMAL PRINTER MECHANISM  
TECHNICAL REFERENCE

U00111642600

# LTPD245A/B, LTPD345A/B THERMAL PRINTER MECHANISM TECHNICAL REFERENCE

**Document Number U00111642600**

First Edition

June 2008

Copyright © 2008 by Seiko Instruments Inc.  
All rights reserved.

Seiko Instruments Inc. (hereinafter referred to as "SII") has prepared this technical reference for use by SII personnel, licensees, and customers. The information contained herein is the property of SII and shall not be reproduced in whole or in part without the prior written approval of SII.

SII reserves the right to make changes without notice to the specifications and materials contained herein and shall not be responsible for any damages (including consequential) caused by reliance on the materials presented, including but not limited to typographical, arithmetic, or listing errors.

SII ● is a trademark of Seiko Instruments Inc.

## PREFACE

This technical reference describes the specifications and basic operating procedures for the LTPD245A/B and LTPD345A/B thermal printer mechanism (hereinafter referred to as “printer”).

The LTPD245A/B and LTPD345A/B have the following model.

- LTPD245A-384-E
- LTPD245B-384-E
- LTPD345A-576-E
- LTPD345B-576-E

This technical reference usually describes information common to any printer unless otherwise specified. If the information is different depending on models, specific model names are mentioned clearly.

Chapter 1 “Precautions” describes safety, design, and handling precautions. Read it thoroughly before designing so that you are able to use the product properly.

SII has not investigated the intellectual property rights of the sample circuits included in this technical reference. Fully investigate the intellectual property rights of these circuits before using. In particular, SII reserves the industrial property rights for the heat storage simulation described in Chapter 3. Using it for the other printers is infringement on the industrial property rights.

The printer complies with EU RoHS Directive (2002/95/EC)

The printer contains “Pb”, the details are described below.

- Printer mechanism : a particular copper alloy parts, a particular component in glass of the electronic parts

\* Lead-containing items listed above are exempt from RoHS (2002/95/EC).

## TABLE OF CONTENTS

Section	Page
<b>CHAPTER 1 PRECAUTIONS</b>	
1.1	SAFETY PRECAUTIONS ..... 1-2
1.2	DESIGN AND HANDLING PRECAUTIONS ..... 1-3
1.2.1	Design Precautions ..... 1-3
1.2.2	Handling Precautions ..... 1-4
1.2.3	Precautions on Discarding ..... 1-5
<b>CHAPTER 2 FEATURES</b>	
<b>CHAPTER 3 SPECIFICATIONS</b>	
3.1	GENERAL SPECIFICATIONS ..... 3-1
3.2	HEAT ELEMENT DIMENSIONS ..... 3-3
3.3	STEP MOTOR ..... 3-4
3.3.1	General Specifications ..... 3-4
3.3.2	Sample Drive Circuit ..... 3-5
3.3.3	Excitation Sequence ..... 3-6
3.3.4	Motor Start/Stop Method ..... 3-7
3.3.5	Motor Drive Method ..... 3-8
3.3.6	Motor Drive Precautions ..... 3-15
3.4	THERMAL HEAD ..... 3-16
3.4.1	Structure of the Thermal Head ..... 3-16
3.4.2	Print Position of the Data ..... 3-17
3.4.3	Electrical Characteristics of Thermal Head ..... 3-18
3.4.4	Timing Chart ..... 3-20
3.4.5	Thermal Head Heat Element Resistance ..... 3-20
3.4.6	Maximum Current Consumption ..... 3-21
3.5	CONTROLLING THE ACTIVATION PULSE WIDTH FOR THERMAL HEAD ..... 3-22
3.5.1	Calculation of Activation Pulse Width ..... 3-22
3.5.2	Calculation of Printing Energy ..... 3-22
3.5.3	Adjustment of Thermal Head Resistance ..... 3-23
3.5.4	Adjustment of Thermal Head drive Voltage ..... 3-24
3.5.5	Setting of Activation Pause Time ..... 3-24
3.5.6	Adjustment by Thermal Head Activation Pulse Period ..... 3-24
3.5.7	Calculation Sample for the Activation Pulse Width ..... 3-25
3.5.8	Temperature Characteristics of Thermistor ..... 3-27
3.5.9	Detecting Abnormal Temperature of the Thermal Head ..... 3-29
3.6	OUT-OF-PAPER SENSOR ..... 3-30
3.7	PLATEN POSITION SENSOR ..... 3-31
3.7.1	General Specifications ..... 3-31
3.7.2	Platen Position Sensor Precautions ..... 3-31
<b>CHAPTER 4 CONNECTING TERMINALS</b>	
4.1	RECOMMENDED CONNECTOR FOR EXTERNAL CIRCUITS ..... 4-1
4.2	CONNECTING TERMINALS ..... 4-1

## CHAPTER5 PRINT DRIVE METHOD

5.1	MOTOR AND THERMAL HEAD DRIVE METHOD .....	5-1
5.2	THERMAL HEAD DIVISION DRIVE METHOD.....	5-4
5.3	PRECAUTIONS FOR PRINT DRIVE .....	5-5

## CHAPTER6 OUTER CASE DESIGN GUIDE

6.1	SECURING THE PRINTER MAIN BODY .....	6-1
	6.1.1 How to Mount the Printer Main Body.....	6-1
	6.1.2 Recommended Screws .....	6-4
	6.1.3 Precautions for Securing the Printer Main Body .....	6-4
6.2	SECURING THE PLATEN BLOCK.....	6-5
	6.2.1 How to Mount the Platen Block .....	6-5
	6.2.2 Recommended Screw .....	6-6
	6.2.3 Precautions for Securing the Platen Block.....	6-6
6.3	CONNECT THE PRINTER TO FRAME GROUND (FG) .....	6-7
	6.3.1 How to Connect the Printer to Frame Ground (FG) .....	6-7
6.4	DESIGN THE PLATEN RELEASE LEVER.....	6-8
6.5	LAYOUT OF THE PRINTER AND PAPER .....	6-9
6.6	WHERE TO MOUNT THE PAPER HOLDER .....	6-10
6.7	DESIGN PAPER EXIT .....	6-11
	6.7.1 Design the Shape of the Paper Exit .....	6-11
	6.7.2 Design the Paper Cutter .....	6-12
6.8	PRECAUTIONS FOR DESIGNING THE OUTER CASE.....	6-13

## CHAPTER7 EXTERNAL DIMENSIONS

## CHAPTER8 HANDLING METHOD

8.1	PROCEDURES FOR INSTALLING/UNINSTALLING THE THERMAL PAPER .....	8-1
	8.1.1 Procedures for Installing/Uninstalling the Thermal paper .....	8-1
	8.1.2 Precautions for Installing the Thermal Paper .....	8-2
8.2	PRECAUTIONS FOR CLEANING THE THERMAL HEAD.....	8-3
	8.2.1 Procedures for Cleaning the Thermal Head.....	8-3
	8.2.2 Precautions for Cleaning the Thermal Head .....	8-3

## TABLES

Table		Page
Table 3-1	General Specifications .....	3-1
Table 3-2	General Specifications of the Step Motor.....	3-4
Table 3-3	Excitation Sequence.....	3-6
Table 3-4	Maximum Motor Drive Pulse Rate .....	3-8
Table 3-5	Acceleration Steps (LTPD245) (1) .....	3-10
Table 3-6	Acceleration Steps (LTPD245) (2) .....	3-11
Table 3-7	Acceleration Steps (LTPD345) .....	3-13
Table 3-8	Maximum Drive Time and Drive Ratio .....	3-14
Table 3-9	DST Blocks and Activated Heating Elements(LTPD245) .....	3-17
Table 3-10	DST Blocks and Activated Heating Elements(LTPD345) .....	3-17
Table 3-11	Electrical Characteristics of Thermal Head(LTPD245) .....	3-18
Table 3-12	Electrical Characteristics of Thermal Head(LTPD345) .....	3-19
Table 3-13	Thermal Head Heat Element Resistance.....	3-20
Table 3-14	Standard printing energy and Temperature coefficient.....	3-23
Table 3-15	Activation Pulse Width.....	3-25
Table 3-16	Temperature Characteristics.....	3-28
Table 3-17	Out-of-paper Sensor.....	3-30
Table 3-18	General Specifications of Platen Position Sensor.....	3-31
Table 4-1	Recommended Connectors .....	4-1
Table 4-2	Terminal Assignments of the Connecting Terminal (LTPD245) .....	4-2
Table 4-3	Terminal Assignments of the Connecting Terminal (LTPD345) .....	4-4
Table 6-1	Allowable Dimensions .....	6-5

## FIGURES

Figure		Page
Figure 3-1	Heat Element Dimensions .....	3-3
Figure 3-2	Print Area .....	3-3
Figure 3-3	Sample Drive Circuit .....	3-5
Figure 3-4	Input Voltage Waveforms for the Sample Drive Circuit .....	3-6
Figure 3-5	Motor Start/Stop Timing Chart .....	3-7
Figure 3-6	Thermal Head Block Diagram(LTPD245) .....	3-16
Figure 3-7	Print Position of the Data(LTPD245).....	3-17
Figure 3-8	Thermal Head Drive Timing Chart .....	3-20
Figure 3-9	Thermistor Resistance vs. Temperature.....	3-27
Figure 3-10	Sample External Circuit of the Out-of-paper Sensor .....	3-30
Figure 3-11	Sample External Circuit of the Platen Position Sensor.....	3-31
Figure 4-1	Connecting Terminals .....	4-1
Figure 5-1	Timing Chart for Driving Using Six Divisions (LTPD245) .....	5-2
Figure 5-2	Timing Chart for Driving Using One Division (LTPD245) .....	5-2
Figure 6-1	Dimensions for Positioning and Securing the Printer Main Body (LTPD245A) .....	6-2
Figure 6-2	Dimensions for Positioning and Securing the Printer Main Body (LTPD245B) .....	6-2
Figure 6-3	Dimensions for Positioning and Securing the Printer Main Body (LTPD345A) .....	6-3
Figure 6-4	Dimensions for Positioning and Securing the Printer Main Body (LTPD345B) .....	6-3
Figure 6-5	Dimensions for Positioning and Securing the Platen Block.....	6-5
Figure 6-6	External Dimensions and Motion of the Platen Release Lever .....	6-8
Figure 6-7	Recommended Layout between the Printer and the Paper.....	6-9
Figure 6-8	Recommended Paper Holder Dimensions .....	6-10
Figure 6-9	Paper Path .....	6-11
Figure 6-10	Blade Edge.....	6-12
Figure 7-1	External Dimensions of the Platen Block (LTPD245) .....	7-2
Figure 7-2	External Dimensions of the Printer (LTPD245A) .....	7-3
Figure 7-3	External Dimensions of the Printer (LTPD245B) .....	7-4
Figure 7-4	External Dimensions of the Platen Block (LTPD345) .....	7-5
Figure 7-5	External Dimensions of the Printer (LTPD345A) .....	7-6
Figure 7-6	External Dimensions of the Printer (LTPD345B) .....	7-7
Figure 8-1	Loading the Thermal Paper (1) .....	8-1
Figure 8-2	Loading the Thermal Paper (2) .....	8-2
Figure 8-3	Cleaning Position of the Thermal Head .....	8-3

## **CHAPTER 1**

### **PRECAUTIONS**

Read through this technical reference to design a product and to operate the printer properly. Pay special attention to the precautions noted in each section for details. Information contained in this technical reference is subject to change without notice.

For the latest information, contact our sales representative.

Sufficient evaluation and confirmation should be performed with the designed outer case mounted, to ensure proper use of the printer.

SII shall not be liable for any damages and/or loss that are caused by improper handling of the printer, any use not contained in this technical reference or that result from the outer case, unless such damages and/or loss originate from the printer itself.

SII has not investigated the intellectual property rights of the sample circuits included in this technical reference. Fully investigate the intellectual property rights of these circuits before using.

The printer is designed and manufactured to be mounted onto general electronic equipment. If high reliability is required of the printer in respect to hazardous influences on the body or life and loss to property, redundant design of the entire system should be carried out and verify the performance with your actual device before commercialization. And our sales representative should be informed as such in advance.

Follow the precautions listed below when designing a product using the printer. Include any necessary precautions into your operation manual to ensure safe operation of your product by users.

## 1.1 SAFETY PRECAUTIONS

Follow the precautions listed below when designing a product using the printer. Include any necessary precautions into your operation manual and attach warning labels to your products to ensure safe operation.

- **Precautions to prevent the thermal head from overheating**

When the thermal head heat elements are continuously activated by a CPU or other malfunction, the thermal head may overheat and may cause smoke and fire. Follow the method described in Chapter 3 “Detecting abnormal temperatures by hardware” to monitor the temperature of the thermal head to prevent overheating. Turn the printer off immediately if any abnormal conditions occur.

- **Precautions for rising temperatures of the thermal head**

Temperature of the thermal head and its peripherals rises very high during and immediately after printing. Be sure to design the outer case to prevent users from burn injuries by touching them. Place warning labels to warn users to ensure safe operation. As for thermal head cleaning, warn users to allow the thermal head to cool before cleaning. In order to allow cooling, secure clearance between the thermal head and the outer case when designing the outer case.

- **Precautions for rising temperatures of the motor**

Temperature of the motor and its peripherals rises very high during and immediately after printing. Be sure to design the outer case to prevent users from burn injuries by touching them. Place warning labels to warn users to ensure safe operation. In order to allow cooling, secure clearance between the motor and the outer case when designing the outer case.

- **Precautions for sharp edges of the printer**

The printer may have some sharp edges and cutting surfaces of the metal parts. Be sure to design the outer case to prevent the users from injuring himself/herself by touching the sharp edges and place warning labels to warn users to ensure safe operation.

- **Precautions for motor drive**

The hair may get caught in the exposed platen and the gears. Control the motor not to drive when the outer case and the platen block are in open state. Also, make sure to design the outer case so as not to touch the platen and the gears and also prevent any objects from getting caught. Place warning labels to warn users to ensure safe operation.

## 1.2 DESIGN AND HANDLING PRECAUTIONS

To maintain the primary performance of the printer and to prevent future problems from occurring, follow the precautions below.

### 1.2.1 Design Precautions

- Apply power in the following manner:  
At power on : 1)  $V_{dd}$  → 2)  $V_P$   
At shut down : 1)  $V_P$  → 2)  $V_{dd}$
- When turning the power on or off, or during not printing, always disable the DST terminals.
- If too much energy is applied to the thermal head, it may overheat and become damaged. Always use the printer with the specified amount of energy shown in Chapter 3 “CONTROLLING THE ACTIVATION PULSE WIDTH FOR THERMAL HEAD”.
- Use C-MOS IC chips for CLK,  $\overline{LAT}$ , DI and DST signals of the thermal head.
- To prevent the thermal head from being damaged by static electricity:  
1) Connect on the printer main body and the platen block to the Frame Ground (FG) of the outer case. See Chapter 6 “OUTER CASE DESIGN GUIDE” for details.  
2) Connect the GND terminal (SG) to FG through approximately 1 M $\Omega$  resistance.
- Keep the  $V_P$  power off while not printing in order to prevent the thermal head from electrolytic corrosion. In addition, design the product so that the signal GND of the thermal head and the frame GND of the printer become the same electric potential.
- Make the wire resistance between the power supply ( $V_P$  and GND) and the printer (connecting terminals) as small as possible (below 50m $\Omega$ ). Keep distance from signal lines to reduce electrical interference.
- A surge voltage between  $V_P$  and GND should not exceed 10V.
- For noise countermeasure, connect a 0.1 $\mu$ F capacitor between  $V_{dd}$  and GND pins near the connector.
- Always detect the outputs of the platen position sensor and out-of-paper sensor. Never activate the thermal head when the platen block is in open state and when there is no thermal paper. Incorrect activation of the thermal head may reduce the life of the thermal head and the platen and may damage them.
- Design the product so that a tension force is not applied to the FPC. The FPC could be moved by setting/releasing the platen block, so design the product so that the FPC has enough play after connected it. The tension force may cause some print problems and may damage the FPC.
- A pause time between thermal head activations of the same heat element shall be secured more than 0.5ms. Pay attention to when using one division printing or when a thermal head activation time becomes longer. If activating for a long time without the pause time, the thermal head may become damaged.
- Noise and vibration during printing vary depending on the motor pulse rate. Verify the performance with your actual device.
- Paper feed force can be decreased depending on the motor pulse rate. Verify the performance with your actual device.
- Do not perform continuous printing to prevent the motor from overheating. Refer to Chapter 3 “Motor Drive Method” to set a pause time.

- Design the paper supply system in accordance with Chapter 6 “OUTER CASE DESIGN GUIDE”. When the paper supply position is improper, print difficulty or paper detection difficulty will be caused and the surface of thermal paper may get scratched. Verify the performance with your actual device.
- Paper feeding may be confused with several dot lines when printing is started from waiting status. When printing and paper feeding are interrupted and then started printing, as this may cause the paper feeding be confused. It especially affects printing of bit images. Always feed the thermal paper for more than 48 steps at start up or do not interrupt printing.
- To prevent degradation in the print quality due to the backlash of the paper drive system, feed the thermal paper for 48 steps or more at the initialization, at a time after setting/releasing the platen block, and a time after cutting with a tear bar.
- Do not feed the thermal paper backwards no more than 9mm. Surface of thermal paper may get scratched by backward feed. The backward feed may cause paper skew and jams depending on paper roll layout and designing of paper holder. Be sure to confirm performance with your product before using the backward feed.
- Metal parts may become discolored and rusted due to the operational environment. Consider these factors regarding appearance.
- Do not use labeling paper, 2-ply thermal paper, and thermal paper with thickness of 86µm or thicker.
- If printing at a high print ratio for longer length, non-printing area may be colored due to an accumulation of heat. Verify the performance with your actual device.
- Design the outer case to ensure enough space to allow the users to handle the platen release lever easily with fingers.
- A door on the outer case that holds the platen block must be set by pushing the center of the platen block. If only one end of the platen block is set, a print defect, and/or a paper jam will occur. Verify the performance with your actual device. In order to be pushed the center of the platen block to set it, put an indication to do so.
- If the printer main body and the platen block are not placed in proper position, the print defect and the paper jam may occur. Therefore, pay special attention to it when designing the outer case. For the position relation between the printer main body and the platen block, see Chapter 6 “OUTER CASE DESIGN GUIDE”.
- If designing the outer case with a structure to bring the platen block up automatically using a spring property after released, make sure not to apply more than enough force to bring the platen block up. If designing a structure that the only one side of the outer case is brought up, the position relation between the printer main body with the movable blade unit and the platen block with the fixed blade unit will be improperly and will result in the print defect or the cut failure. Verify the performance with your actual device.

### 1.2.2 Handling Precautions

Incorrect handling may reduce the efficiency of the printer and cause damage. Handle the printer with the following precautions.

Also, include any necessary precautions so that users handle the printer with care.

- When handling the printer, make sure to use antistatic clothing and to ground yourself to prevent the thermal head from damaged by static electricity. Especially take care of the thermal head heat element and the connecting terminal.
- In order to prevent the thermal head from damage and to avoid the print defect, warn the users not to touch the thermal head and the sensor directly when handling the printer like replacing thermal paper.
- Never connect or disconnect the connecting terminal with the power on.

- Do not apply stress to the FPC while connecting and disconnecting them. Otherwise the FPC may become damaged.
- Using anything other than the specified thermal paper does not guarantee print quality and life of the thermal head.  
The followings are examples of trouble:
  - (1) Poor printing quality due to low thermal sensitivity
  - (2) Abrasion of the thermal head due to paper surface roughness
  - (3) Printing stuck and unusual noise due to sticking the thermal layer of the thermal paper to the thermal head
  - (4) Printing fade due to low preservability of the thermal paper
  - (5) Electrolytic corrosion of the thermal head due to inferior paper
- Do not use a paper roll with glued end or folded end. In case of using such roll papers, replace to a new one before the end of the paper roll is shown up.
- Do not hit or scratch the surface of the thermal head with any sharp or hard object. This could damage the thermal head.
- After the printer has been left not in use for long period of time, the platen could be deformed and resulted in print quality deteriorated. In this case, feed thermal paper for a while to recover deformation of the platen. If the thermal head is remained in contact with the platen without thermal paper for a long time, the platen and the thermal head may be stuck together and cause paper feed difficulty. If facing this problem, release the platen block and set it back again before starting printing.
- Do not release the platen block during printing; otherwise this may reduce the efficiency of the printer.
- When printing at a high print ratio in a low temperature or high humidity environment, the vapor from the thermal paper during printing may cause condensation to form on the printer or may soil the thermal paper itself. Prevent the thermal head from a drop of water. It may cause electrolytic corrosion of the thermal head. If condensed, power off the  $V_P$  until dried.
- Warn the users not to pull the thermal paper and to change an angle of the paper coming out while printing. Otherwise, the paper jam may occur.
- Never loosen the screws that fasten respective parts of the printer. Loosened screws may reduce the efficiency of the performance of the printer mechanism.
- When setting the platen block, the reduction gear may interfere with the platen gear and may cause the platen block to not be set. In such a case, release the platen block and set it again.
- Never pull out the thermal paper while the platen block is set. The printer may become damaged.
- Do not apply stress to the platen block while printing. The print defect may occur.
- The printer is not waterproof and drip proof. Prevent contact with water and do not operate with wet hands as it may damage the printer or may cause a short circuit or fire.
- The printer is not dust proof. Never use the printer in a dusty place, as it may damage the thermal head and paper drive system.
- Do not use the printer in corrosive gas and siloxane atmosphere as it may cause the contact failure.

### 1.2.3 Precautions on Discarding

When discarding used printers, discard them according to the disposal regulations and rules of each respective district.

## CHAPTER 2

### FEATURES

The printer is a compact printer that adopts a thermal line dot printing method. It can be used with measuring instruments and analyzer, a POS, a communication terminal device, or a data terminal device.

The printer has the following features:

- **High resolution Printing**

A high-density print head of 8 dots/mm produces clear and precise printing.

- **Compact**

LTPD245A:

Dimensions : W69.0mm x D30.0mm x H15.0mm

LTPD245B:

Dimensions : W69.0mm x D15.0mm x H30.0mm

LTPD245A/B:

Mass : approx. 40 g

LTPD345A:

Dimensions : W91.0mm x D30.0mm x H15.0mm

LTPD345B:

Dimensions : W91.0mm x D15.0mm x H30.0mm

LTPD345A/B:

Mass : approx. 58 g

- **High print speed<sup>\*1</sup>**

LTPD245A/B:

Maximum 100mm/s print is available.

LTPD345A/B:

Maximum 80mm/s print is available.

- **Easy operation**

Platen block open mechanism provides easy paper installation.

- **Maintenance Free**

No cleaning and no maintenance required.

- **Low noise**

Thermal printing technology realizes low-noise print.

\*1 Print speed differs depending on working conditions.

## CHAPTER 3 SPECIFICATIONS

### 3.1 GENERAL SPECIFICATIONS

Table 3-1 lists the general specifications of the printer.

**Table 3-1 General Specifications**

(1/2)

Items	Specifications			
	LTPD245A	LTPD245B	LTPD345A	LTPD345B
Printing method	Thermal dot line printing			
Total dots per line	384 dots		576 dots	
Printable dots per line	384 dots		576 dots	
Simultaneously activated dots	96 dots		96 dots <sup>NOTE(1)</sup>	
Resolution	W8 dots/mm × H16 dots/mm			
Paper feed pitch	0.03125mm			
Maximum print speed <sup>NOTE(2)</sup>	100mm/s <sup>NOTE(2)</sup>		80mm/s <sup>NOTE(2)</sup>	
Print width	48mm		72mm	
Paper width	58 <sup>0</sup> <sub>-1</sub> mm		80 <sup>0</sup> <sub>-1</sub> mm	
Thermal head temperature detection	Thermistor			
Platen position detection	Mechanical switch			
Out-of-paper detection	Reflection type photo interrupter			
Operating voltage range				
V <sub>P</sub> line	4.75 to 9.5V			
V <sub>dd</sub> line	2.7 to 5.25V			
Current consumption				
V <sub>P</sub> line Thermal head drive	5.49A max. (at 9.5V) <sup>NOTE(3)</sup>		5.40A max. (at 9.5V) <sup>NOTE(3)</sup>	
Motor drive	0.60A max.			
V <sub>dd</sub> line Thermal head Logic	0.10A max.			

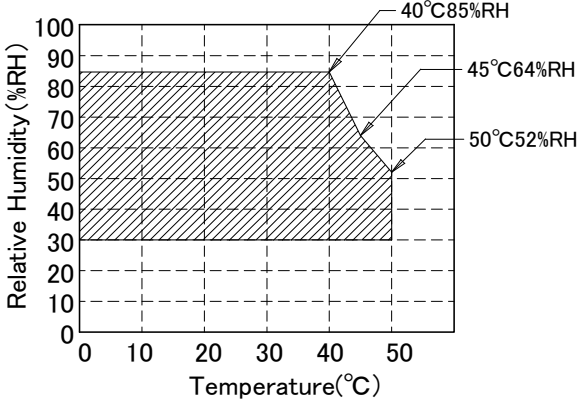
Items	Specifications			
	LTPD245A	LTPD245B	LTPD345A	LTPD345B
Operating temperature and humidity range	-10 to 50°C (Non condensing) 			
Storage temperature range	-35 to 75°C (Non condensing)			
Life span (at 25°C and rated energy)	Activation pulse resistance	100 million pulses or more <sup>NOTE(4)</sup>		
	Abrasion resistance	50km or more (excluding damage caused by dust and foreign materials)		
Paper feed force	0.49N (50gf) or more			
Paper hold force	0.78N (80gf) or more			
Dimensions (excluding convex part)	W69.0mm × D30.0mm × H15.0mm	W69.0mm × D15.0mm × H30.0mm	W91.0mm × D30.0mm × H15.0mm	W91.0mm × D15.0mm × H30.0mm
Mass	approx. 40g		approx. 58g	
Specified thermal paper	Nippon Paper  Oji Paper  Mitsubishi Paper mills limited Jujo Thermal  Mitsubishi Hi-Tech Paper  Papierfabrik August Koehler AG KSP  KANZAN  Appleton		TF50KS-E2D TP50KJ-R TL69KS-LH PD160R-63 PD160R-N P220VBB-1 AP50KS-D AF50KS-E AP50FZ F5041 P5045 KT55F20 P300 P350 P350-2.0 KIP370 KIP470 KF50 KPR440 Alpha900-3.4	

NOTE (1) Up to 128 dots are available if the  $V_P$  is 7.9 or lower.

NOTE (2) Print speed changes according to the processing speed of the controller and print pulse width.

NOTE (3) The value when the number of simultaneously activated dots is the maximum dots.

NOTE (4) Excluded when the same dots are printed continuously.

Only when using the specified thermal paper and the activation pulse width specified in 3.5

### 3.2 HEAT ELEMENT DIMENSIONS

Figure 3-1 shows heat element dimensions. Figure 3-2 shows print area.

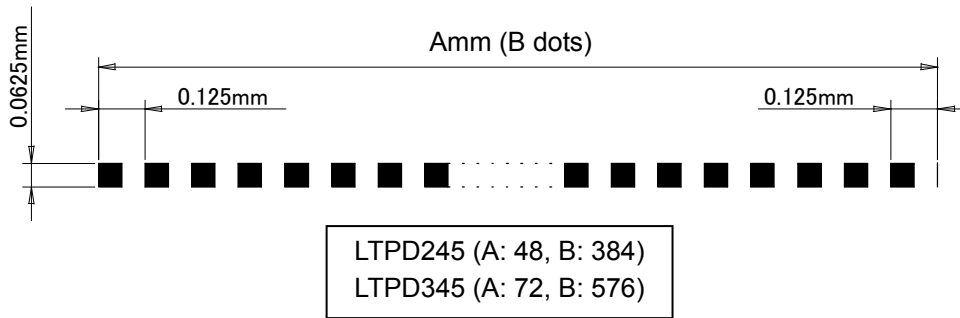

**Figure 3-1 Heat Element Dimensions**

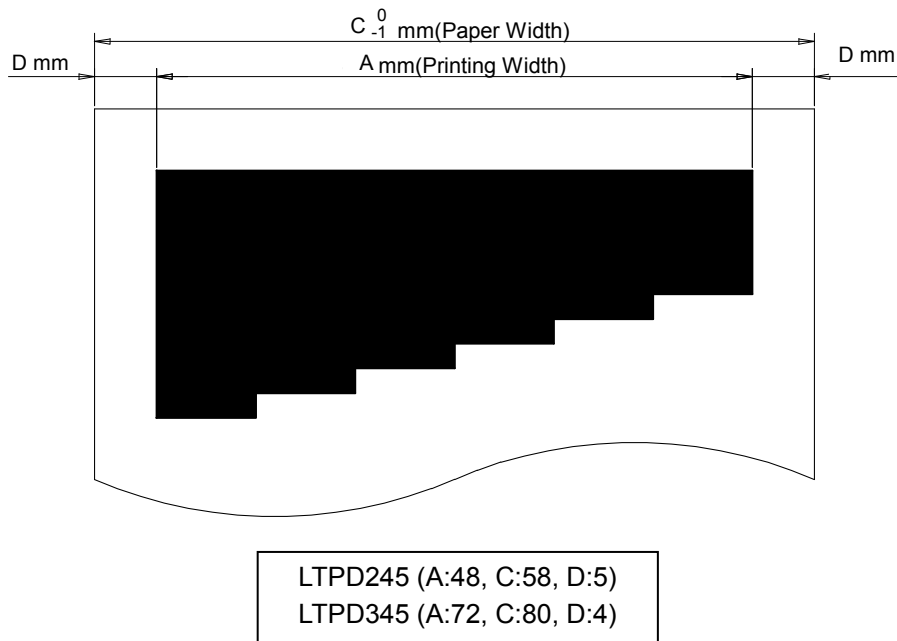

**Figure 3-2 Print Area**

### 3.3 STEP MOTOR

#### 3.3.1 General Specifications

Table 3-2 shows general specifications of the step motor.

**Table 3-2 General Specifications of the Step Motor**

Item	Specifications	
	LTPD245	LTPD345
Type	PM type step motor	
Drive method	Bi-polar chopper	
Excitation	1-2 phase	
Winding resistance per phase	12Ω/phase ±10%	
Motor drive voltage	V <sub>P</sub> : 4.75 to 9.5V	
Motor controlled current	300 mA/phase	
Drive pulse rate	3200pps max.	2560pps max.

### 3.3.2 Sample Drive Circuit

A sample drive circuit for the motor is shown in Figure 3-3.

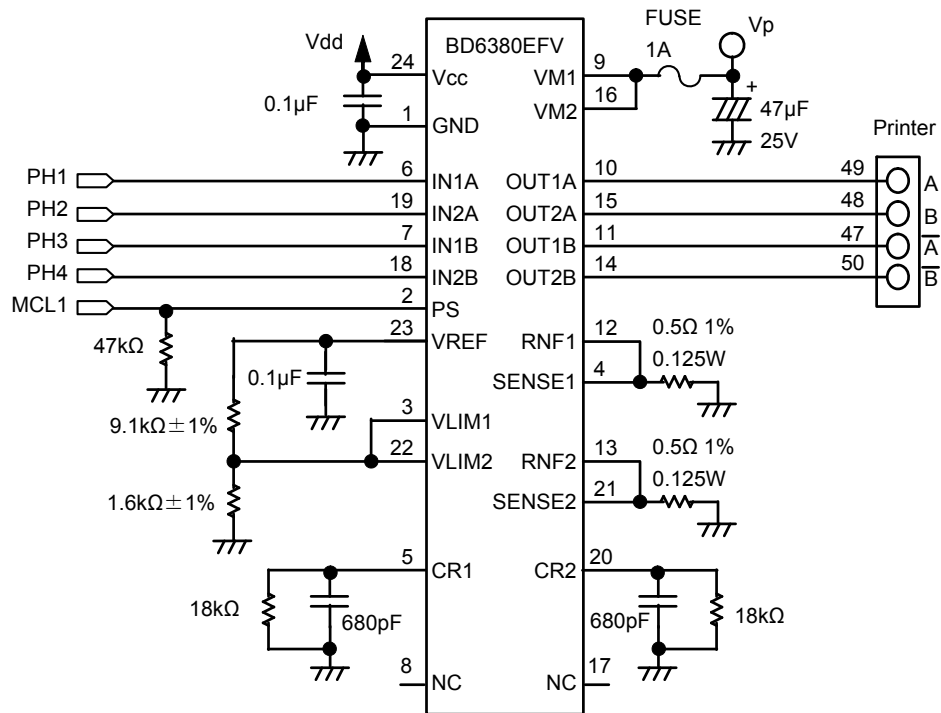

\* Recommended motor driver : BD6380EFV(Rohm)

Figure 3-3 Sample Drive Circuit

### 3.3.3 Excitation Sequence

Drive the motor with 1-2 phase excitation. One step of the motor drive signal feeds the paper 0.03125 mm. One dot line is consisted of 4 steps. When the voltage signal shown in Figure 3-4 is input to the motor drive circuit shown in Figure 3-3, the printer feeds the paper in the normal direction when the motor is excited in order of step 1, step 2, step 3, step 4, step 5, step 6, step7, step 8, step 1, step 2, . . . . , as shown in Table 3-3.

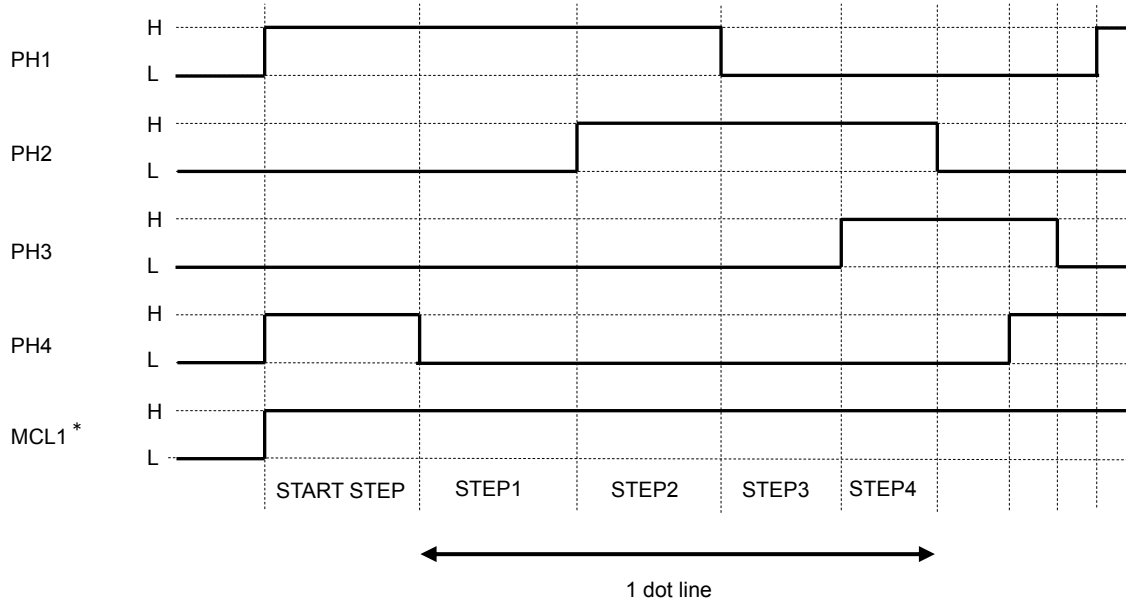

\*: Set MCL1 to "High" while the motor is driven.

**Figure 3-4 Input Voltage Waveforms for the Sample Drive Circuit**

**Table 3-3 Excitation Sequence**

	Input signal				Output signal			
	PH1	PH2	PH3	PH4	A	B	$\bar{B}$	$\bar{A}$
Step1	H	L	L	L	H	OPEN	L	OPEN
Step2	H	H	L	L	H	H	L	L
Step3	L	H	L	L	OPEN	H	OPEN	L
Step4	L	H	H	L	L	H	H	L
Step5	L	L	H	L	L	OPEN	H	OPEN
Step6	L	L	H	H	L	L	H	H
Step7	L	L	L	H	OPEN	L	OPEN	H
Step8	H	L	L	H	H	L	L	H

### 3.3.4 Motor Start/Stop Method

Refer to the timing chart in Figure 3-5 when designing the control circuit or software for starting and stopping the motor. Also note the following precautions:

(1) Start step

To start the motor from the pause (no excitation) state, shift the motor to the sequence of print step after exciting the same phase as that of the stop step for the first acceleration step time ( $5000 \mu s$ ) of the acceleration step.

To restart the motor from the stop step, immediately shift the motor to the sequence of print step.

(2) Stop step

To stop the motor, excite the same phase as the last one in the printing step for 65ms.

(3) Pause state

In the pause state, do not excite the motor to prevent to the motor from overheating. Even when the motor is not excited, holding torque of the motor prevents the paper from moving.

Input signals for a sample drive circuit are shown in Figure 3-5.

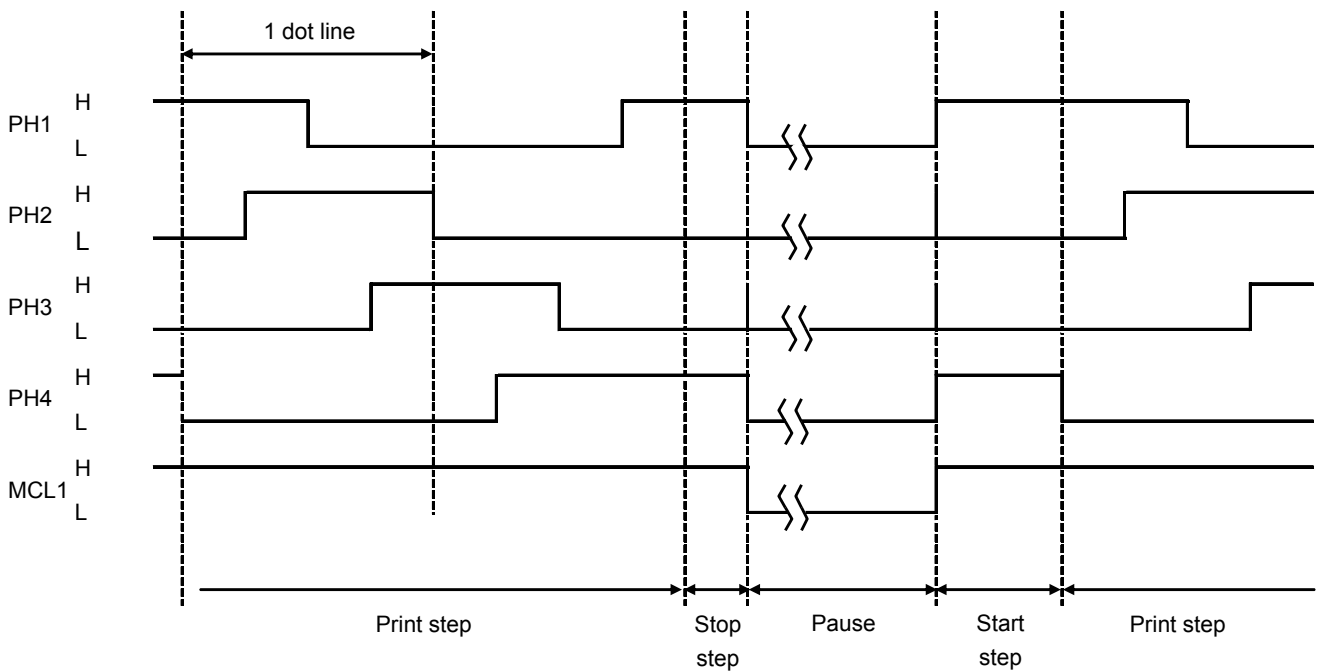

Figure 3-5 Motor Start/Stop Timing Chart

### 3.3.5 Motor Drive Method

Drive the motor by the following methods.

#### (1) Motor drive pulse rate

During paper feeding, the motor should be driven lower than the value obtained by equation (1).

Equation (1):

$$\text{LTPD245: } P_M = V_P \times 534 - 1399 \text{ (pps)}$$

$$\text{LTPD345: } P_M = V_P \times 400 - 840 \text{ (pps)}$$

$P_M$  : Maximum motor drive pulse rate at  $V_P$  (pps)  
However, LTPD245: 3200pps max. and LTPD345: 2560pps max.

$V_P$  : Motor drive voltage (V)

**Table 3-4 Maximum Motor Drive Pulse Rate**

Vp	Maximum motor drive pulse rate	
	LTPD245	LTPD345
4.75 V	1198 pps	1060 pps
5.5 V	1598 pps	1360 pps
6.0 V	1865 pps	1560 pps
7.2 V	2506 pps	2040 pps
8.0 V	2933 pps	2360 pps
8.5 V	3200 pps	2560 pps
9.5 V	3200 pps	2560 pps

#### (2) Motor speed control

When driving the motor, the acceleration control is required to maintain the paper feed force of start up. If acceleration of the motor does not perform correctly, the motor may step out if it has a heavy workload. Accelerate the speed sequentially up to the maximum motor drive pulse rate  $P_M$  according to the Table 3-5, Table 3-6 and Table 3-7 Acceleration Steps.

The method for accelerating the motor is as follows;

1. The start step is 5000 $\mu$ s.
2. The first step is the first acceleration step time.
3. The second step is the second acceleration step time.
4. Hereinafter, the "n"th step is the "n" acceleration step time.
5. After accelerating up to the maximum motor drive pulse rate  $P_M$ , the motor drives at a constant speed.

Available to print during acceleration.

The activation time of the thermal head can be longer than the motor step time depending on the type of the thermal paper, content of the printing and use condition. In that case, the 1st step time and the 2nd step time of the half dot line in the motor should be equal and sum of those should be equal to the half dot line of the thermal head activation.

Follow the procedures below if :

Unable to accelerate the speed for the reasons above even if following the Table 3-5, Table 3-6 and Table 3-7.

The speed has been reduced at a certain speed and then accelerates the speed again.

For the next step time after reducing the speed, output the “n”th acceleration step time that should be shorter than the previous step time and should be the biggest.

(ex) In the case of Figure 3-5, if the previous step time is  $900\mu\text{s}$ , the next step should be the 10th acceleration step ( $880\mu\text{s}$ ).

Hereinafter, accelerate the speed sequentially up to the maximum motor drive pulse rate  $P_M$  according to Table 3-5, Table 3-6 and Table 3-7. The recommended acceleration table of the LTPD245 depends on the thermal paper in use.

**Table 3-5 Acceleration Steps (LTPD245) (1)**

<b>Number of Steps</b>	<b>Speed (pps)</b>	<b>Step Time (μs)</b>	<b>Number of Steps</b>	<b>Speed (pps)</b>	<b>Step Time (μs)</b>
Start	-	5000	37	2274	440
1	270	3707	38	2305	434
2	436	2291	39	2337	428
3	565	1769	40	2367	422
4	673	1485	41	2398	417
5	768	1302	42	2428	412
6	853	1172	43	2457	407
7	931	1074	44	2487	402
8	1004	996	45	2515	398
9	1072	933	46	2544	393
10	1136	880	47	2572	389
11	1197	836	48	2600	385
12	1255	797	49	2628	381
13	1310	763	50	2655	377
14	1364	733	51	2683	373
15	1415	707	52	2709	369
16	1465	683	53	2736	365
17	1513	661	54	2762	362
18	1560	641	55	2788	359
19	1605	623	56	2814	355
20	1649	606	57	2840	352
21	1692	591	58	2865	349
22	1734	577	59	2891	346
23	1775	563	60	2916	343
24	1815	551	61	2940	340
25	1854	539	62	2965	337
26	1893	528	63	2989	335
27	1930	518	64	3013	332
28	1967	508	65	3037	329
29	2004	499	66	3061	327
30	2039	490	67	3085	324
31	2075	482	68	3108	322
32	2109	474	69	3131	319
33	2143	467	70	3154	317
34	2176	459	71	3177	315
35	2209	453	72	3200	313
36	2242	446	—	—	—

**Table 3-6 Acceleration Steps (LTPD245) (2)**

Object thermal paper :

The paper with thickness of 80μm or thicker (TL69KS-LH, KIP370, KIP470, Alpha900-3.4)

(1/2)

Number of Steps	Speed (pps)	Step Time (μs)	Number of Steps	Speed (pps)	Step Time (μs)
Start	—	5000	31	1600	625
1	208	4805	32	1627	615
2	337	2970	33	1653	605
3	436	2293	34	1679	596
4	519	1925	35	1704	587
5	593	1688	36	1729	578
6	658	1519	37	1754	570
7	719	1392	38	1778	562
8	774	1291	39	1802	555
9	827	1209	40	1826	548
10	876	1141	41	1850	541
11	923	1083	42	1873	534
12	968	1033	43	1896	528
13	1011	989	44	1918	521
14	1052	951	45	1940	515
15	1092	916	46	1963	510
16	1130	885	47	1984	504
17	1167	857	48	2006	499
18	1203	831	49	2027	493
19	1238	808	50	2048	488
20	1272	786	51	2069	483
21	1305	766	52	2090	478
22	1338	748	53	2111	474
23	1369	730	54	2131	469
24	1400	714	55	2151	465
25	1430	699	56	2171	461
26	1460	685	57	2191	456
27	1489	671	58	2210	452
28	1518	659	59	2230	448
29	1546	647	60	2249	445
30	1573	636	—	—	—

Number of Steps	Speed (pps)	Step Time ( $\mu$ s)	Number of Steps	Speed (pps)	Step Time ( $\mu$ s)
61	2268	441	91	2781	360
62	2287	437	92	2797	358
63	2306	434	93	2812	356
64	2325	430	94	2827	354
65	2343	427	95	2842	352
66	2361	423	96	2858	350
67	2380	420	97	2873	348
68	2398	417	98	2888	346
69	2416	414	99	2903	345
70	2433	411	100	2917	343
71	2451	408	101	2932	341
72	2469	405	102	2947	339
73	2486	402	103	2962	338
74	2503	399	104	2976	336
75	2520	397	105	2991	334
76	2538	394	106	3005	333
77	2554	391	107	3019	331
78	2571	389	108	3034	330
79	2588	386	109	3048	328
80	2605	384	110	3062	327
81	2621	382	111	3076	325
82	2638	379	112	3090	324
83	2654	377	113	3104	322
84	2670	375	114	3118	321
85	2686	372	115	3132	319
86	2702	370	116	3146	318
87	2718	368	117	3159	317
88	2734	366	118	3173	315
89	2750	364	119	3186	314
90	2765	362	120	3200	313

**Table 3-7 Acceleration Steps (LTPD345)**

<b>Number of Steps</b>	<b>Speed (pps)</b>	<b>Step Time (μs)</b>	<b>Number of Steps</b>	<b>Speed (pps)</b>	<b>Step Time (μs)</b>
Start	-	5000	37	1819	550
1	216	4634	38	1844	542
2	349	2864	39	1869	535
3	452	2211	40	1894	528
4	539	1856	41	1918	521
5	614	1627	42	1942	515
6	683	1465	43	1966	509
7	745	1342	44	1989	503
8	803	1245	45	2012	497
9	857	1166	46	2035	491
10	909	1100	47	2058	486
11	957	1044	48	2080	481
12	1004	996	49	2102	476
13	1048	954	50	2124	471
14	1091	917	51	2146	466
15	1132	883	52	2168	461
16	1172	853	53	2189	457
17	1210	826	54	2210	453
18	1248	802	55	2231	448
19	1284	779	56	2251	444
20	1319	758	57	2272	440
21	1354	739	58	2292	436
22	1387	721	59	2312	432
23	1420	704	60	2332	429
24	1452	689	61	2352	425
25	1483	674	62	2372	422
26	1514	660	63	2391	418
27	1544	648	64	2411	415
28	1574	635	65	2430	412
29	1603	624	66	2449	408
30	1632	613	67	2468	405
31	1660	603	68	2486	402
32	1687	593	69	2505	399
33	1714	583	70	2523	396
34	1741	574	71	2542	393
35	1768	566	72	2560	391
36	1793	558	—	—	—

(3) Preventing Overheat

To prevent the motor from overheating, the drive time and drive ratio are limited.  
Follow the Table 3-8 shown below to set an operating time and a pause time of the motor.

**Table 3-8 Maximum Drive Time and Drive Ratio**

Drive pulse rate (pps)	Maximum continuous drive time (s)	Motor drive voltage Vp (V)				
		9.5V ≥ Vp > 8.5V	8.5V ≥ Vp > 7.5V	7.5V ≥ Vp > 6.5V	6.5V ≥ Vp > 5.5V	5.5V ≥ Vp ≥ 4.75V
		Drive ratio	Drive ratio	Drive ratio	Drive ratio	Drive ratio
320 to 560	450	85%	85%	85%	85%	90%
560 to 800	450	85%	85%	85%	90%	90%
800 to 1040	450	85%	85%	85%	90%	95%
1040 to 1280	450	85%	85%	90%	95%	100%
1280 to 1520	450	85%	90%	90%	100%	100%
1520 to 1760	450	85%	90%	95%	100%	100%
1760 to 2000	455	85%	90%	100%	100%	×
2000 to 2240	465	85%	95%	100%	100%	×
2240 to 2480	485	90%	100%	100%	×	×
2480 to 2720	515	90%	100%	100%	×	×
2720 to 2960	575	95%	100%	×	×	×
2960 to 3200	665	95%	100%	×	×	×
3200	1445	95%	100%	×	×	×

× : Not Allowed to use

$$\text{Drive Ratio(\%)} = \frac{\text{Drive Time}}{\text{Drive Time} + \text{Pause Time}} \times 100(\%)$$

### 3.3.6 Motor Drive Precautions

- Using the motor drive circuit other than the circuit shown in "Section 3.3.2 Sample Drive Circuit" may not ensure the specified efficiency.
- To prevent degradation in the print quality due to the backlash of the paper drive system, feed the paper for 48 steps or more at the initialization, at a time after setting/releasing the platen block, and a time after cutting with a paper cutter. During this time, drive the motor with constant speed at the 1st acceleration step.
- When printing, change the motor drive pulse rate depending on the operational conditions such as voltage, temperature, and the number of activated dots. (See Chapter 5 "PRINT DRIVE METHOD" for details)
- When printing, change the motor drive pulse rate so that the activation pulse width of the thermal head does not exceed the sum of the two-step times of the motor. (See Chapter 5 "PRINT DRIVE METHOD" for details).
- Do not feed the thermal paper backwards no more than 9mm. Surface of thermal paper may get scratched by backward feed. The backward feed may cause paper skew and jams depending on paper roll layout and designing of paper holder. Be sure to confirm performance with your product before using the backward feed.
- Do not print intermittently (Do not repeat printing and stopping in a short interval.)  
If doing so, print quality may be decreased due to unevenness of the paper feed pitch.
- Always perform the start and the stop steps for both character print and bit image print.
- For the motor stop, a minimum one dot line of motor feed is required from the step that thermal head was activated. If the motor is stopped at the step that the thermal head has been activated, paper feed difficulty may be caused due to sticking of the thermal paper to the thermal head.
- Sound and vibration during printing vary depending on the motor drive pulse rate. Verify the performance with your actual device.

### 3.4 THERMAL HEAD

The thermal head consists of heat elements and a thermal head driver that drives and controls the heat elements.

The data from the DI terminal is transferred to the shift register at the rising edge of the CLK signal.

The data is stored into the latch register by making  $\overline{\text{LAT}}$  signal "Low" after one line data is transferred. The heat elements are activated by making DST signal "High" in accordance with the stored print data.

In the LTPD245, a division printing by 6 blocks is available. Each block has 64 dots heat elements.

In the LTPD345 at 7.9V or lower, a division printing by 64 dots in 1 block and 128 dots in 4 blocks each are available. The divided printing is effective for a high print ratio printing because the peak current can be cut down with the reduction of the average print speed.

#### 3.4.1 Structure of the Thermal Head

Figure 3-6 shows the thermal head block diagram when driving the LTPD245.

Table 3-9 and Table 3-10 show the relationship between DST blocks and activated heating elements.

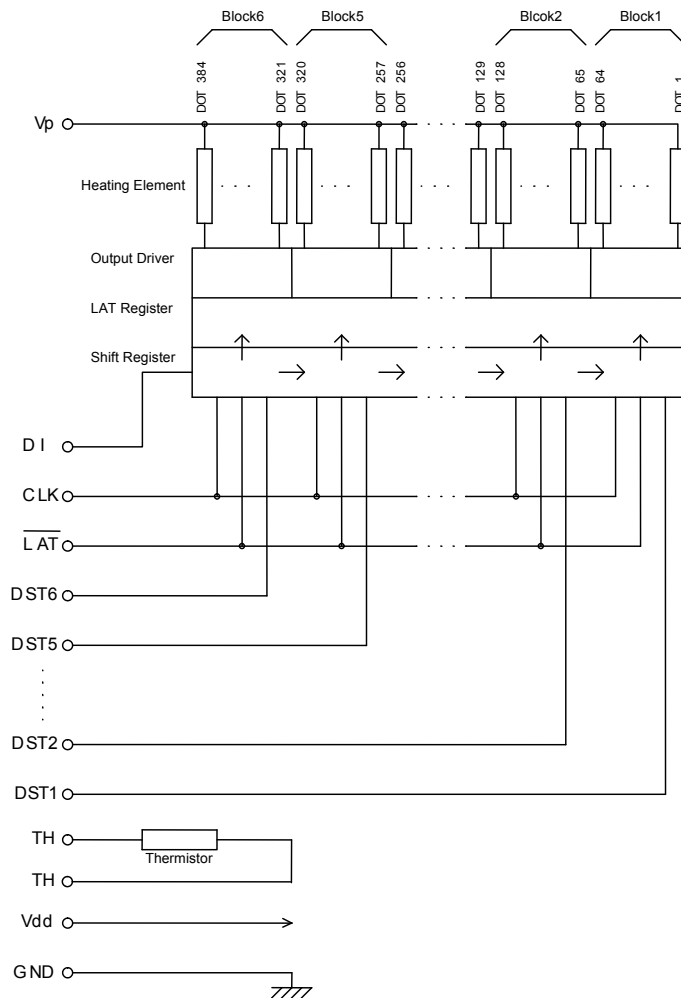

**Figure 3-6 Thermal Head Block Diagram(LTPD245)**

**Table 3-9 DST Blocks and Activated Heating Elements(LTPD245)**

Block	DST Number	Heating Element Number	Dots/DST
1	DST 1	1 to 64	64
2	DST 2	65 to 128	64
3	DST 3	129 to 192	64
4	DST 4	193 to 256	64
5	DST 5	257 to 320	64
6	DST 6	321 to 384	64

**Table 3-10 DST Blocks and Activated Heating Elements(LTPD345)**

Block	DST Number	Heating Element Number	Dots/DST
1	DST 1	1 to 128	128
2	DST 2	129 to 256	128
3	DST 3	257 to 320	64
4	DST 4	321 to 448	128
5	DST 5	449 to 576	128

**3.4.2 Print Position of the Data**

384-bit data (#1 to #384) transferred through DI terminals are printed when driving the LTPD245 as shown in Figure 3-7.

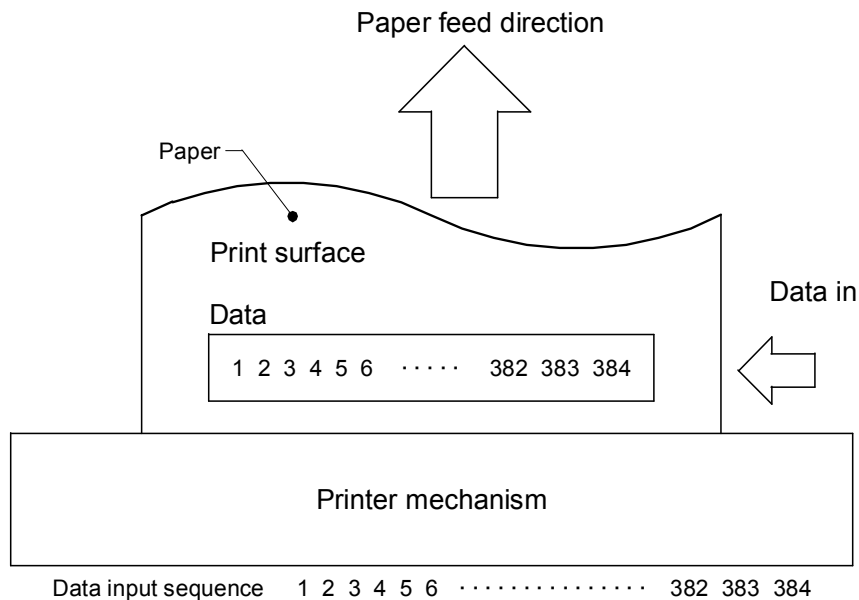

**Figure 3-7 Print Position of the Data(LTPD245)**

### 3.4.3 Electrical Characteristics of Thermal Head

Table 3-11 and Table 3-12 show electrical characteristics of thermal head.

**Table 3-11 Electrical Characteristics of Thermal Head(LTPD245)**

(at 25 °C)

Item	Symbol	Conditions	Rated value			Unit
			MIN	TYP	MAX	
Thermal head heat element resistance	$R_H$		166.0	173.0	180.0	$\Omega$
Thermal Head drive voltage	$V_P$		4.75	-	9.5	V
Thermal Head drive current	$I_P$	at the number of simultaneously activated dots = 96	-	-	5.49	A
Logic voltage	$V_{dd}$		2.7	5	5.25	V
Logic current	$I_{dd}$	$f_{DI}=1/2f_{CLK}$	-	-	36	mA
Input voltage	High	$V_{IH}$ CLK, DI, $\overline{LAT}$ , DST	$0.8V_{dd}$	-	$V_{dd}$	V
	Low	$V_{IL}$ CLK, DI, $\overline{LAT}$ , DST	0	-	$0.2 V_{dd}$	V
DI input current	High	$I_{IH DI}$ $V_{IH} = V_{dd}$	-	-	0.5	$\mu A$
	Low	$I_{IL DI}$ $V_{IL} = 0V$	-	-	-0.5	$\mu A$
DST input current (High active)	High	$I_{IH DST}$ $V_{dd}$	-	-	55	$\mu A$
	Low	$I_{IL DST}$ $V_{IL} = 0V$	-	-	-0.5	$\mu A$
CLK input current	High	$I_{IH CLK}$ $V_{IH} = V_{dd}$	-	-	1.0	$\mu A$
	Low	$I_{IL CLK}$ $V_{IL} = 0V$	-	-	-1.0	$\mu A$
$\overline{LAT}$ input current	High	$I_{IH \overline{LAT}}$ $V_{IH} = V_{dd}$	-	-	1.0	$\mu A$
	Low	$I_{IL \overline{LAT}}$ $V_{IL} = 0V$	-	-	-1.0	$\mu A$
CLK frequency	$f_{CLK}$	$2.7V \leq V_{dd} < 3.0 V$	-	-	5	MHz
		$3.0 \leq V_{dd} \leq 5.25V$	-	-	8	MHz
CLK pulse width	$t_1$	See the Timing Chart. $2.7V \leq V_{dd} < 3.0 V$	50	-	-	ns
		$3.0 \leq V_{dd} \leq 5.25V$	30	-	-	ns
DI setup time	$t_2$	See the Timing Chart. $2.7V \leq V_{dd} < 3.0 V$	70	-	-	ns
		$3.0 \leq V_{dd} \leq 5.25V$	30	-	-	ns
DI hold time	$t_3$	See the Timing Chart. $2.7V \leq V_{dd} < 3.0 V$	40	-	-	ns
		$3.0 \leq V_{dd} \leq 5.25V$	30	-	-	ns
$\overline{LAT}$ setup time	$t_4$	See the Timing Chart.	100	-	-	ns
$\overline{LAT}$ pulse width	$t_5$	See the Timing Chart.	100	-	-	ns
$\overline{LAT}$ hold time	$t_6$	See the Timing Chart.	50	-	-	ns
DST setup time	$t_7$	See the Timing Chart.	300	-	-	ns
$\overline{LAT}$ wait time	$t_8^*$	See the Timing Chart. $2.7V \leq V_{dd} < 3.0 V$	36	-	-	$\mu s$
		$3.0 \leq V_{dd} \leq 5.25V$	30	-	-	$\mu s$

\*: If MIN at " $\overline{LAT}$  wait time" in the table cannot be secured, it may cause Vp voltage fluctuations.

**Table 3-12 Electrical Characteristics of Thermal Head(LTPD345)**

(at 25 °C )

Item	Symbol	Conditions	Rated value			Unit
			MIN	TYP	MAX	
Thermal head heat element resistance	$R_H$		168.9	176.0	183.1	$\Omega$
Thermal Head drive voltage	$V_P$		4.75	-	9.5	V
Thermal Head drive current	$I_P$	at the number of simultaneously activated dots = 96	-	-	5.4	A
Logic voltage	$V_{dd}$		2.7	5	5.25	V
Logic current	$I_{dd}$	$f_{DI}=1/2f_{CLK}$	-	-	54	mA
Input voltage	High	$V_{IH}$ CLK, DI, $\overline{LAT}$ , DST	$0.8V_{dd}$	-	$V_{dd}$	V
	Low	$V_{IL}$ CLK, DI, $\overline{LAT}$ , DST	0	-	$0.2 V_{dd}$	V
DI input current	High	$I_{IH}$ DI $V_{IH} = V_{dd}$	-	-	0.5	$\mu A$
	Low	$I_{IL}$ DI $V_{IL} = 0V$	-	-	-0.5	$\mu A$
DST input current (High active)	High	$I_{IH}$ DST $V_{dd}$	-	-	110	$\mu A$
	Low	$I_{IL}$ DST $V_{IL} = 0V$	-	-	-1.0	$\mu A$
CLK input current	High	$I_{IH}$ CLK $V_{IH} = V_{dd}$	-	-	1.5	$\mu A$
	Low	$I_{IL}$ CLK $V_{IL} = 0V$	-	-	-1.5	$\mu A$
$\overline{LAT}$ input current	High	$I_{IH}$ $\overline{LAT}$ $V_{IH} = V_{dd}$	-	-	1.5	$\mu A$
	Low	$I_{IL}$ $\overline{LAT}$ $V_{IL} = 0V$	-	-	-1.5	$\mu A$
CLK frequency	$f_{CLK}$	$2.7V \leq V_{dd} < 3.0V$	-	-	5	MHz
		$3.0 \leq V_{dd} \leq 5.25V$	-	-	8	MHz
CLK pulse width	t1	See the Timing Chart. $2.7V \leq V_{dd} < 3.0V$	50	-	-	ns
		$3.0 \leq V_{dd} \leq 5.25V$	30	-	-	ns
DI setup time	t2	See the Timing Chart. $2.7V \leq V_{dd} < 3.0V$	70	-	-	ns
		$3.0 \leq V_{dd} \leq 5.25V$	30	-	-	ns
DI hold time	t3	See the Timing Chart. $2.7V \leq V_{dd} < 3.0V$	40	-	-	ns
		$3.0 \leq V_{dd} \leq 5.25V$	30	-	-	ns
$\overline{LAT}$ setup time	t4	See the Timing Chart.	100	-	-	ns
$\overline{LAT}$ pulse width	t5	See the Timing Chart.	100	-	-	ns
$\overline{LAT}$ hold time	t6	See the Timing Chart.	50	-	-	ns
DST setup time	t7	See the Timing Chart.	300	-	-	ns
$\overline{LAT}$ wait time	t8*	See the Timing Chart. $2.7V \leq V_{dd} < 3.0V$	36	-	-	$\mu s$
		$3.0 \leq V_{dd} \leq 5.25V$	30	-	-	$\mu s$

\*: If MIN at " $\overline{LAT}$  wait time" in the table cannot be secured, it may cause Vp voltage fluctuations.

### 3.4.4 Timing Chart

Figure 3-8 shows a thermal head drive timing chart.

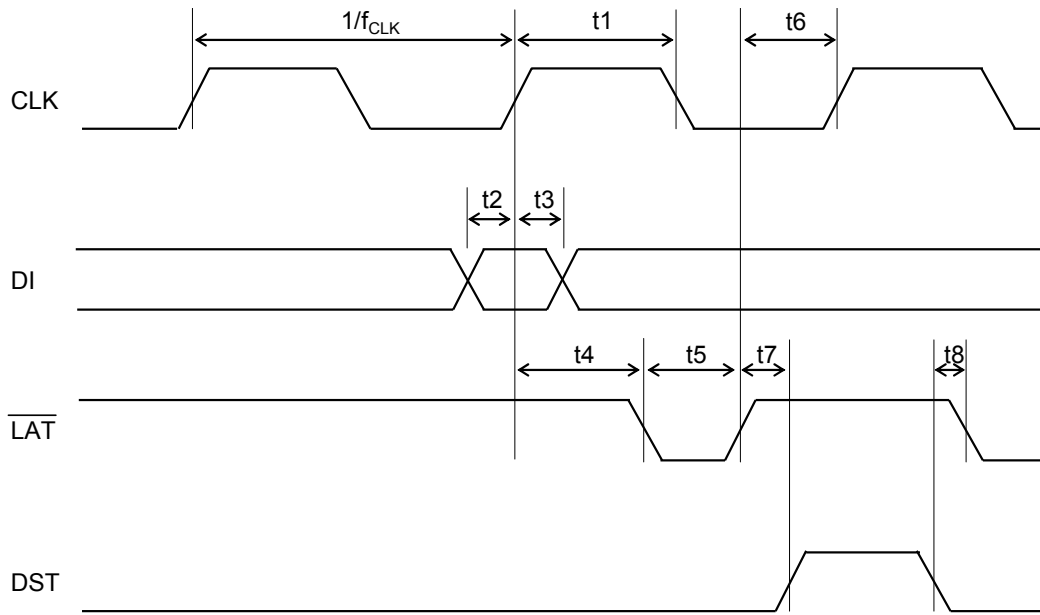

Figure 3-8 Thermal Head Drive Timing Chart

### 3.4.5 Thermal Head Heat Element Resistance

Table 3-13 shows resistance of the thermal head heat element of the printer.

Table 3-13 Thermal Head Heat Element Resistance

Thermal Head Heat Element Resistance	
LTPD245	LTPD345
166.0 to 180.0Ω	168.9 to 183.1Ω

### 3.4.6 Maximum Current Consumption

Since the maximum current consumption may reach the values calculated using equation (2) when the thermal head is driven, the number of simultaneously activated dots should be determined not to exceed power supply capacity. Also, allowable current for the cable material and the voltage drop on the cable should be cared well.

Equation (2):

$$I_P = \frac{N_{SA} \times V_P}{R_{Hmin}}$$

- $I_P$  : Maximum current consumption (A)
- $N_{SA}$  : Number of simultaneously activated dots (logical block)
- $V_P$  : Thermal head drive voltage (V)
- $R_{Hmin}$  : Minimum thermal head heat element resistance
  - 166.0 ( $\Omega$ ) (LTPD245)
  - 168.9 ( $\Omega$ ) (LTPD345)

### 3.5 CONTROLLING THE ACTIVATION PULSE WIDTH FOR THERMAL HEAD

To execute high quality printing using the printer, the activation pulse width according to printer use condition must be used. Control printing with the activation pulse width calculated by the following sequence. Printing at too high voltage or too long activation pulse width may shorten the life of the thermal head.

#### 3.5.1 Calculation of Activation Pulse Width

Each value can be calculated according to the steps in Section 3.5.2 to 3.5.6 and the activation pulse width “t” can be calculated by substituting each value into the equation (3).

Equation (3):

$$t = \frac{E \times R}{V^2} \times C$$

t	:	Thermal head pulse width (ms)	
E	:	Printing energy (mJ)	See section 3.5.2
R	:	Adjusted resistance ( $\Omega$ )	See section 3.5.3
V	:	Adjusted voltage (V)	See section 3.5.4
C	:	Thermal head activation pulse period coefficient	See section 3.5.6

#### 3.5.2 Calculation of Printing Energy

The printing energy “E” can be calculated using equation (4) as the appropriate printing energy is different depending on each specified thermal paper and the temperature of the thermal head.

Equation (4):

$$E = E_{25} - T_C \times (T_X - 25)$$

$E_{25}$	:	Standard printing energy	See Table 3-14
$T_C$	:	Temperature coefficient	See Table 3-14
$T_X$	:	temperature detected by thermistor ( $^{\circ}\text{C}$ ) * <sup>1</sup>	

\*<sup>1</sup>Measure the temperature using the resistance of the built-in thermistor on the thermal head.  
For the thermistor resistance value at  $T_X$  ( $^{\circ}\text{C}$ ), see Section 3.5.8.

**Table 3-14 Standard printing energy and Temperature coefficient**

Thermal paper		Standard printing energy (mJ)	Temperature coefficient	
Nippon Paper	TF50KS-E2D	0.2489	0.002885	
	TP50KJ-R	0.2745	0.002950	
	TL69KS-LH	0.3286	0.002341	
Oji Paper	PD160R-63	0.2393	0.001678	
	PD160R-N	0.3068	0.003668	
Mitsubishi Paper mills limited	P220VBB-1	0.2864	0.003028	
Jujo Thermal	AP50KS-D	25°C or higher	0.2796	0.003093
		Less than 25°C	0.2798	0.002085
	AF50KS-E	0.2651	0.002981	
	AP50FZ	0.2934	0.002707	
Mitsubishi Hi-Tech Paper	F5041	0.2576	0.002847	
	P5045	0.3262	0.003601	
Papierfabrik August Koehler AG	KT55F20	0.3068	0.003668	
KSP	P300	0.2703	0.002797	
	P350	0.2462	0.002723	
	P350-2.0	0.2347	0.002778	
	KIP370	0.3206	0.002328	
	KIP470	0.2759	0.003447	
KANZAN	KF50	0.2774	0.002183	
	KPR440	0.2966	0.001951	
Appleton	Alpha900-3.4	0.2476	0.003539	

### 3.5.3 Adjustment of Thermal Head Resistance

The adjusted resistance “R” can be calculated using equation (5) to adjust the thermal head resistance as a voltage drop is caused by wiring resistance.

Equation (5):

$$R = \frac{(R_H + R_i + (R_C + r_C) \times N_{SA})^2}{R_H}$$

$R_H$	: Thermal head heat element resistance	173.0 (Ω)(LTPD245) 176.0 (Ω)(LTPD345)
$R_i$	: Wiring resistance in the thermal head	9 (Ω) <sup>*1</sup>
$R_C$	: Common terminal wiring resistance in the thermal head	
$r_C$	: Wiring resistance between Vp and GND (Ω) <sup>*2</sup>	0.20 (Ω)

\*1  $V_{dd}$  is 5.0V.  $R_i$  is 13(Ω) if  $V_{dd}$  is 3.0 or 3.3V

\*2 The resistance is a serial resistance of the wire and switching circuit of relay between control terminal and power supply.

### 3.5.4 Adjustment of Thermal Head drive Voltage

The adjusted voltage “V” can be calculated using equation (6) as the printing density changes by the difference of the thermal head drive voltage.

Equation (6):

$$V = 1.368421 \times V_P - 2.8$$

$V_P$  : Thermal head drive voltage (V)

### 3.5.5 Setting of Activation Pause Time

In order to protect the thermal head heat elements, when the same heat element dots are activated continuously on the successive dot line, determine the activation pulse period (the time from the start of the preceding activation to the start of the current activation) which meets equation (7) to secure the pause time.

Equation (7):

$$W > t + 500 (\mu s)$$

$W$  : 2 step (1/2 dot line) driving cycle ( $\mu s$ )

### 3.5.6 Adjustment by Thermal Head Activation Pulse Period

The thermal head activation pulse period coefficient “C” can be calculated using equations (8) as the printing density varies by the thermal head activation pulse period (equivalent for motor drive pulse rate).

Equation (8):

$$C = 1 - \frac{1020 \times V_P - 1650}{(V_P - 3.55) \times (W + 1350) + 1920}$$

### 3.5.7 Calculation Sample for the Activation Pulse Width

Table 3-15 lists the calculation samples of the activation pulse width calculated using equation (3) and the values obtained using equations (4) to (8).

**Table 3-15 Activation Pulse Width**

(1/2)  
Unit : ms

Vp [V]	Tx [°C]	Motor drive pulse rate [pps]														
		400	600	800	1000	1200	1400	1600	1800	2000	2200	2400	2600	2800	3000	3200
4.75	-10	3.977	3.446	3.059	2.764	2.531	x	x	x	x	x	x	x	x	x	x
	0	3.649	3.162	2.806	2.536	2.323	x	x	x	x	x	x	x	x	x	x
	10	3.321	2.878	2.554	2.308	2.114	x	x	x	x	x	x	x	x	x	x
	20	2.994	2.594	2.302	2.080	1.905	x	x	x	x	x	x	x	x	x	x
	30	2.666	2.310	2.050	1.852	1.696	x	x	x	x	x	x	x	x	x	x
	40	2.338	2.025	1.798	1.624	1.488	x	x	x	x	x	x	x	x	x	x
	50	2.010	1.741	1.545	1.396	1.279	x	x	x	x	x	x	x	x	x	x
	60	1.682	1.457	1.293	1.168	1.070	x	x	x	x	x	x	x	x	x	x
	70	1.354	1.173	1.041	0.941	0.862	x	x	x	x	x	x	x	x	x	x
80	1.026	0.889	0.789	0.713	0.653	x	x	x	x	x	x	x	x	x	x	
5.5	-10	2.650	2.352	2.126	1.948	1.805	1.687	1.589	x	x	x	x	x	x	x	x
	0	2.432	2.158	1.950	1.787	1.656	1.548	1.458	x	x	x	x	x	x	x	x
	10	2.213	1.964	1.775	1.627	1.507	1.409	1.327	x	x	x	x	x	x	x	x
	20	1.995	1.770	1.600	1.466	1.358	1.270	1.196	x	x	x	x	x	x	x	x
	30	1.776	1.576	1.424	1.305	1.210	1.131	1.065	x	x	x	x	x	x	x	x
	40	1.558	1.382	1.249	1.145	1.061	0.992	0.934	x	x	x	x	x	x	x	x
	50	1.339	1.188	1.074	0.984	0.912	0.852	0.803	x	x	x	x	x	x	x	x
	60	1.121	0.994	0.899	0.824	0.763	0.713	0.672	x	x	x	x	x	x	x	x
	70	0.902	0.800	0.723	0.663	0.614	0.574	0.541	x	x	x	x	x	x	x	x
80	0.683	0.606	0.548	0.502	0.465	0.435	0.410	x	x	x	x	x	x	x	x	
6.0	-10	2.081	1.863	1.696	1.562	1.454	1.364	1.289	1.224	x	x	x	x	x	x	x
	0	1.910	1.710	1.556	1.433	1.334	1.252	1.182	1.123	x	x	x	x	x	x	x
	10	1.738	1.556	1.416	1.305	1.214	1.139	1.076	1.022	x	x	x	x	x	x	x
	20	1.567	1.402	1.276	1.176	1.094	1.027	0.970	0.921	x	x	x	x	x	x	x
	30	1.395	1.249	1.136	1.047	0.974	0.914	0.864	0.820	x	x	x	x	x	x	x
	40	1.223	1.095	0.996	0.918	0.855	0.802	0.757	0.719	x	x	x	x	x	x	x
	50	1.052	0.941	0.857	0.789	0.735	0.689	0.651	0.619	x	x	x	x	x	x	x
	60	0.880	0.788	0.717	0.661	0.615	0.577	0.545	0.518	x	x	x	x	x	x	x
	70	0.708	0.634	0.577	0.532	0.495	0.464	0.439	0.417	x	x	x	x	x	x	x
80	0.537	0.481	0.437	0.403	0.375	0.352	0.332	0.316	x	x	x	x	x	x	x	
7.2	-10	1.273	1.153	1.059	0.984	0.921	0.869	0.825	0.786	0.753	0.724	0.698	x	x	x	x
	0	1.168	1.058	0.972	0.902	0.845	0.797	0.757	0.722	0.691	0.664	0.641	x	x	x	x
	10	1.063	0.963	0.885	0.821	0.769	0.726	0.689	0.657	0.629	0.605	0.583	x	x	x	x
	20	0.958	0.868	0.797	0.740	0.693	0.654	0.621	0.592	0.567	0.545	0.526	x	x	x	x
	30	0.853	0.773	0.710	0.659	0.617	0.582	0.553	0.527	0.505	0.485	0.468	x	x	x	x
	40	0.748	0.678	0.623	0.578	0.541	0.511	0.485	0.462	0.443	0.426	0.410	x	x	x	x
	50	0.643	0.583	0.535	0.497	0.465	0.439	0.417	0.397	0.381	0.366	0.353	x	x	x	x
	60	0.538	0.488	0.448	0.416	0.389	0.367	0.349	0.332	0.318	0.306	0.295	x	x	x	x
	70	0.433	0.392	0.360	0.335	0.314	0.296	0.281	0.268	0.256	0.246	0.238	x	x	x	x
80	0.328	0.297	0.273	0.254	0.238	0.224	0.213	0.203	0.194	0.187	0.180	x	x	x	x	
8.0	-10	0.967	0.881	0.812	0.756	0.710	0.671	0.638	0.610	0.585	0.563	0.543	0.526	0.510	x	x
	0	0.888	0.808	0.745	0.694	0.652	0.616	0.586	0.559	0.536	0.516	0.499	0.483	0.468	x	x
	10	0.808	0.735	0.678	0.631	0.593	0.561	0.533	0.509	0.488	0.470	0.454	0.439	0.426	x	x
	20	0.728	0.663	0.611	0.569	0.534	0.505	0.480	0.459	0.440	0.424	0.409	0.396	0.384	x	x
	30	0.648	0.590	0.544	0.507	0.476	0.450	0.428	0.409	0.392	0.377	0.364	0.352	0.342	x	x
	40	0.568	0.518	0.477	0.444	0.417	0.395	0.375	0.358	0.344	0.331	0.319	0.309	0.300	x	x
	50	0.489	0.445	0.410	0.382	0.359	0.339	0.322	0.308	0.295	0.284	0.275	0.266	0.258	x	x
	60	0.409	0.372	0.343	0.320	0.300	0.284	0.270	0.258	0.247	0.238	0.230	0.222	0.216	x	x
	70	0.329	0.300	0.276	0.257	0.242	0.228	0.217	0.207	0.199	0.192	0.185	0.179	0.174	x	x
80	0.249	0.227	0.209	0.195	0.183	0.173	0.165	0.157	0.151	0.145	0.140	0.136	0.132	x	x	

Vp [V]	Tx [°C]	Motor drive pulse rate [pps]														
		400	600	800	1000	1200	1400	1600	1800	2000	2200	2400	2600	2800	3000	3200
8.5	-10	0.829	0.756	0.698	0.651	0.612	0.580	0.551	0.527	0.506	0.487	0.471	0.456	0.443	0.431	0.420
	0	0.760	0.694	0.641	0.598	0.562	0.532	0.506	0.484	0.464	0.447	0.432	0.418	0.406	0.395	0.385
	10	0.692	0.631	0.583	0.544	0.511	0.484	0.460	0.440	0.423	0.407	0.393	0.381	0.370	0.360	0.350
	20	0.624	0.569	0.526	0.490	0.461	0.436	0.415	0.397	0.381	0.367	0.354	0.343	0.333	0.324	0.316
	30	0.555	0.507	0.468	0.437	0.410	0.388	0.370	0.353	0.339	0.327	0.315	0.306	0.297	0.289	0.281
	40	0.487	0.444	0.410	0.383	0.360	0.341	0.324	0.310	0.297	0.286	0.277	0.268	0.260	0.253	0.247
	50	0.419	0.382	0.353	0.329	0.309	0.293	0.279	0.266	0.256	0.246	0.238	0.230	0.224	0.218	0.212
	60	0.350	0.320	0.295	0.275	0.259	0.245	0.233	0.223	0.214	0.206	0.199	0.193	0.187	0.182	0.177
	70	0.282	0.257	0.238	0.222	0.208	0.197	0.188	0.179	0.172	0.166	0.160	0.155	0.151	0.147	0.143
80	0.214	0.195	0.180	0.168	0.158	0.149	0.142	0.136	0.130	0.126	0.121	0.118	0.114	0.111	0.108	
9.5	-10	0.628	0.574	0.532	0.497	0.468	0.444	0.423	0.405	0.389	0.375	0.363	0.351	0.341	0.332	0.324
	0	0.576	0.527	0.488	0.456	0.430	0.407	0.388	0.372	0.357	0.344	0.333	0.322	0.313	0.305	0.297
	10	0.524	0.480	0.444	0.415	0.391	0.371	0.353	0.338	0.325	0.313	0.303	0.294	0.285	0.278	0.271
	20	0.472	0.432	0.400	0.374	0.353	0.334	0.318	0.305	0.293	0.282	0.273	0.265	0.257	0.250	0.244
	30	0.421	0.385	0.357	0.333	0.314	0.298	0.284	0.271	0.261	0.251	0.243	0.236	0.229	0.223	0.217
	40	0.369	0.338	0.313	0.292	0.275	0.261	0.249	0.238	0.229	0.220	0.213	0.207	0.201	0.195	0.190
	50	0.317	0.290	0.269	0.251	0.237	0.224	0.214	0.205	0.197	0.189	0.183	0.178	0.173	0.168	0.164
	60	0.265	0.243	0.225	0.210	0.198	0.188	0.179	0.171	0.164	0.159	0.153	0.149	0.144	0.141	0.137
	70	0.214	0.196	0.181	0.169	0.159	0.151	0.144	0.138	0.132	0.128	0.123	0.120	0.116	0.113	0.110
80	0.162	0.148	0.137	0.128	0.121	0.115	0.109	0.104	0.100	0.097	0.094	0.091	0.088	0.086	0.084	

X : Not allowed to use

Note) The table above is applicable under the following condition:

- Use of thermal paper "TF50KS-E2D"
- Vp and GND wiring resistance :  $r_c = 0$
- The number of simultaneously activated dots :  $N_{SA} = 96$

### 3.5.8 Temperature Characteristics of Thermistor

Calculate the resistance of the thermistor ( $R_x$ ) at the operating temperature  $T_x$  ( $^{\circ}\text{C}$ ) using the following equation (9). Variation of resistance by temperature is shown in Figure 3-9 and Table 3-16.

Equation (9):

$$R_x = R_{25} \times \text{EXP} \left\{ B \times \left( \frac{1}{273 + T_x} - \frac{1}{298} \right) \right\}$$

- $R_x$  : Resistance at  $T_x$   $^{\circ}\text{C}$  ( $\Omega$ )
- $R_{25}$  : Resistance at 25  $^{\circ}\text{C}$        $30 \pm 5\%$  ( $\text{k}\Omega$ )
- $B$  : B value       $3950 \pm 2\%$  (K)
- $T_x$  : Temperature detected by thermistor ( $^{\circ}\text{C}$ )
- EXP (A) : The "A" th power of natural logarithm e (2.71828)

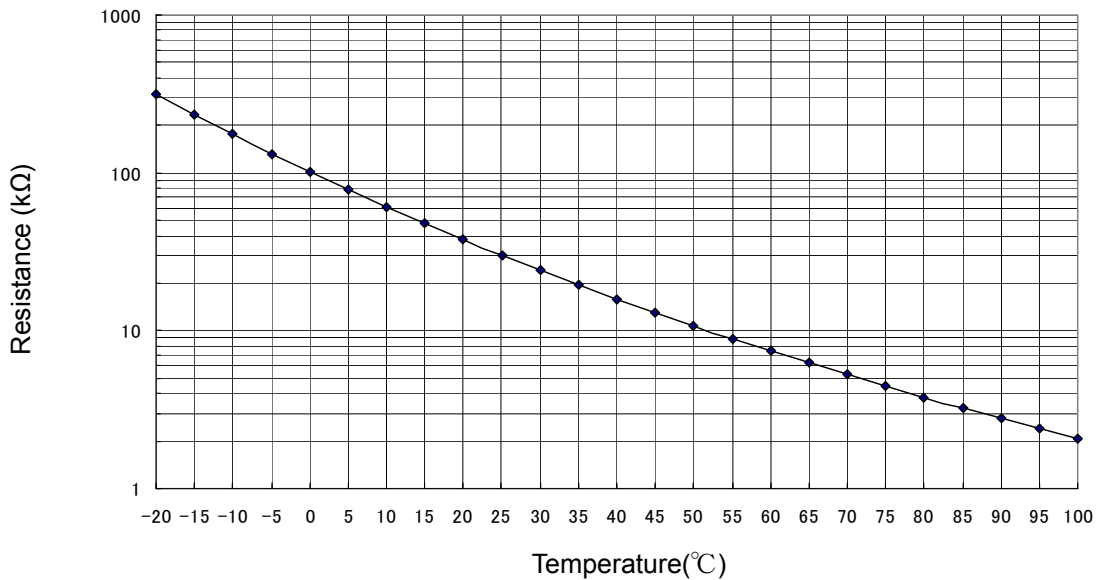

**Figure 3-9 Thermistor Resistance vs. Temperature**

**Table 3-16 Temperature Characteristics**

<b>Temperature (°C)</b>	<b>Thermistor Resistance (kΩ)</b>
-20	316.97
-15	234.22
-10	175.07
-5	132.29
0	100.99
5	77.85
10	60.57
15	47.53
20	37.61
25	30.00
30	24.11
35	19.51
40	15.89
45	13.03
50	10.75
55	8.92
60	7.45
65	6.25
70	5.27
75	4.47
80	3.80
85	3.25
90	2.79
95	2.41
100	2.09

### 3.5.9 Detecting Abnormal Temperature of the Thermal Head

To protect the thermal head and to ensure personal safety, abnormal temperature of the thermal head must be detected by both hardware and software as follows:

#### (1) Detecting abnormal temperatures by software

Design software that will deactivate the heat elements if the thermal head thermistor (TH) detects a temperature higher than 80°C (thermistor resistance  $R_{TH} \leq 3.80 \text{ k}\Omega$ ), and reactivate the heat elements when a temperature lower than 60°C ( $R_{TH} \geq 7.45 \text{ k}\Omega$ ) is detected. If the thermal head continues to be activated at a temperature higher than 80°C, the life of the thermal head may be shortened significantly.

#### (2) Detecting abnormal temperatures by hardware

If the thermal head continues to be activated by malfunction of the control unit (CPU), the software for detecting abnormal temperatures may not function properly, resulting in overheating of the thermal head. Overheating of the thermal head not only may damage the thermal head but also may cause smoke, fire and burn injuries. Always use hardware together with software for detecting abnormal temperatures to ensure personal safety. (If the control unit malfunctions, it may be impossible to prevent damage on the thermal head even if an abnormal temperature is detected by hardware.).

Using a window comparator circuit or similar sensor, design hardware that detects the following abnormal conditions:

- (a) Overheating of the thermal head  
(approximately 100°C or higher ( $R_{TH} \leq 2.09 \text{ k}\Omega$ ))
- (b) Faulty thermistor connection (the thermistor may be open or short-circuited).

If (a) or (b) is detected, immediately turn off the power supply. Reactivate the heat elements after they have returned to normal.

### 3.6 OUT-OF-PAPER SENSOR

The printer has a built-in out-of-paper sensor (reflection type photo interrupter) to detect whether paper is present or not. An external circuit should be designed so that it detects output from the out-of-paper sensor and does not activate the thermal head and motor when there is no paper. Doing not so may cause damage to the thermal head or platen roller or shorten the life of the thermal head significantly. If the motor is driven when there is no paper, a load is put on the paper drive system and the life of the printer may be shortened significantly.

Table 3-17 shows about the out-of-paper sensor used for this printer.

**Table 3-17 Out-of-paper Sensor**

Item	Specification
Type	NJL5902R (Rank B)
Manufacturer	New Japan Radio Co.,Ltd.

Figure 3-10 shows sample external circuit of the out-of-paper sensor.

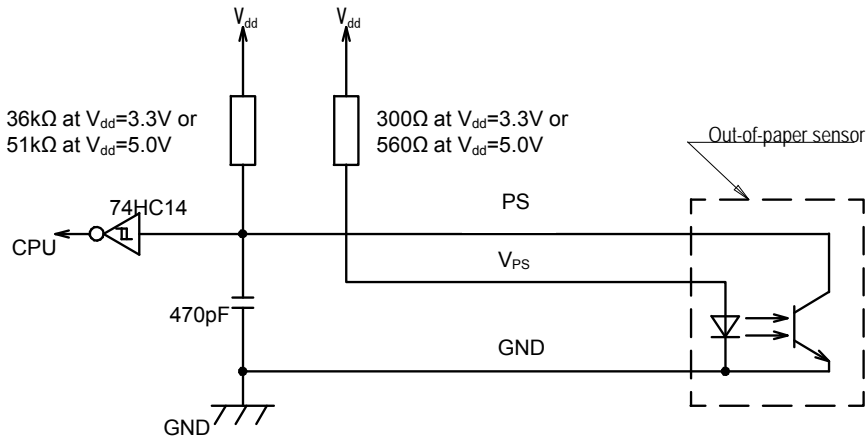

\* The PS signal is "High" when there is no paper.

**Figure 3-10 Sample External Circuit of the Out-of-paper Sensor**

### 3.7 PLATEN POSITION SENSOR

The printer has a built-in platen position sensor for detecting whether the platen block is set or released. This sensor is a mechanical switch which is designed to be on when the platen block is set and to be off when it is released.

The external circuit should be designed to detect output from the platen position sensor and output from the out-of-paper sensor described in 3.8. If the platen open and the no paper are detected, the external circuit should not activate the thermal head. Otherwise, the thermal head may become damaged or its life may be shortened significantly.

Activate the thermal head when the platen block is closed by detecting the output from the platen position detection, and in the paper presence state by detecting the output from the paper sensor.

#### 3.7.1 General Specifications

Table 3-18 shows about the general specification

**Table 3-18 General Specifications of Platen Position Sensor**

Item	Specification
Rated voltage	DC5.0V
Rated current	1mA
Contact resistance	3Ω max.

Figure 3-11 shows sample external circuit of the platen position sensor.

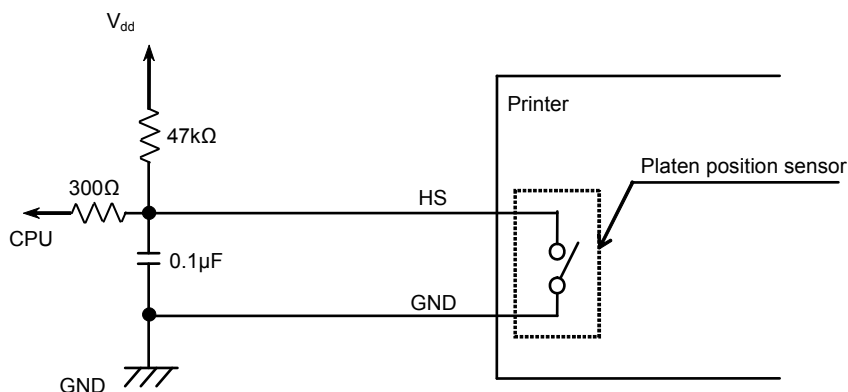

\* The HS signal is "High" when the platen is in an OPENED state.

**Figure 3-11 Sample External Circuit of the Platen Position Sensor**

#### 3.7.2 Platen Position Sensor Precautions

- Be sure that there is a time lag between the time when the thermal head is set and the time when the platen position sensor actually starts detecting.
- Always use the capacitor shown in Figure 3-11 to prevent the switch from malfunctioning due to chattering.

## CHAPTER 4 CONNECTING TERMINALS

### 4.1 RECOMMENDED CONNECTOR FOR EXTERNAL CIRCUITS

Use the recommended connectors listed in Table 4-1 to connect the printer connecting terminals firmly to the external circuits.

**Table 4-1 Recommended Connectors**

Number of Terminals	Recommended Connectors
50	MOLEX INC: 54104-5031 (right angle, top contact, gold plated)

### 4.2 CONNECTING TERMINALS

Figure 4-1 shows the terminal configuration of the connecting terminals and Table 4-2 and Table 4-3 show terminal assignments of the connecting terminals.

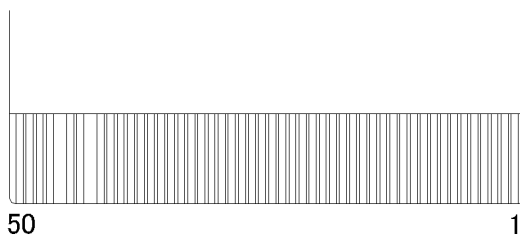

**Figure 4-1 Connecting Terminals**

**Table 4-2 Terminal Assignments of the Connecting Terminal (LTPD245)**

(1/2)

<b>Terminal Number</b>	<b>Signal Name</b>	<b>Description</b>
1	V <sub>P</sub>	Thermal head drive voltage
2	V <sub>P</sub>	Thermal head drive voltage
3	V <sub>P</sub>	Thermal head drive voltage
4	V <sub>P</sub>	Thermal head drive voltage
5	V <sub>P</sub>	Thermal head drive voltage
6	V <sub>P</sub>	Thermal head drive voltage
7	DI	Print data input (serial input)
8	CLK	Synchronizing signal for print data transfer
9	GND	GND
10	GND	GND
11	GND	GND
12	GND	GND
13	GND	GND
14	GND	GND
15	DST6	Thermal head print activation instruction signal (#6 block)
16	DST5	Thermal head print activation instruction signal (#5 block)
17	DST4	Thermal head print activation instruction signal (#4 block)
18	V <sub>dd</sub>	Logic power supply
19	TH2	Thermistor (the one is used for GND)
20	TH1	Thermistor (same as pin #21)
21	TH1	Thermistor (same as pin #20)
22	DST3	Thermal head print activation instruction signal (#3block)
23	DST2	Thermal head print activation instruction signal (#2 block)
24	DST1	Thermal head print activation instruction signal (#1 block)
25	GND	GND
26	GND	GND
27	GND	GND
28	GND	GND
29	GND	GND
30	GND	GND

Terminal Number	Signal Name	Description
31	$\overline{\text{LAT}}$	Print data latch (memory holding)
32	$V_P$	Thermal head drive power
33	$V_P$	Thermal head drive power
34	$V_P$	Thermal head drive power
35	$V_P$	Thermal head drive power
36	$V_P$	Thermal head drive power
37	$V_P$	Thermal head drive power
38	N.C.	No connection
39	PS	Output signal of the paper sensor (Photo-transistor collector)
40	$V_{PS}$	Power supply of the paper sensor (LED anode)
41	GND	GND of the paper sensor (LED cathode, photo-transistor emitter) Platen position sensor GND
42	HS	Platen position sensor output
43	N.C.	No connection
44	FG	FG
45	FG	FG
46	N.C.	No connection
47	$\overline{A}$	Motor drive signal
48	B	Motor drive signal
49	A	Motor drive signal
50	$\overline{B}$	Motor drive signal

**Table 4-3 Terminal Assignments of the Connecting Terminal (LTPD345)**

(1/2)

<b>Terminal Number</b>	<b>Signal Name</b>	<b>Description</b>
1	V <sub>P</sub>	Thermal head drive power
2	V <sub>P</sub>	Thermal head drive power
3	V <sub>P</sub>	Thermal head drive power
4	V <sub>P</sub>	Thermal head drive power
5	V <sub>P</sub>	Thermal head drive power
6	V <sub>P</sub>	Thermal head drive power
7	DI	Print data input (serial input)
8	CLK	Synchronizing signal for print data transfer
9	GND	GND
10	GND	GND
11	GND	GND
12	GND	GND
13	GND	GND
14	GND	GND
15	N.C.	No connection
16	DST5	Thermal head print activation instruction signal (#5 block)
17	DST4	Thermal head print activation instruction signal (#4 block)
18	V <sub>dd</sub>	Logic power supply
19	TH2	Thermistor (the one is used for GND)
20	TH1	Thermistor (same as pin #21)
21	TH1	Thermistor (same as pin #20)
22	DST3	Thermal head print activation instruction signal (#3 block)
23	DST2	Thermal head print activation instruction signal (#2 block)
24	DST1	Thermal head print activation instruction signal (#1 block)
25	GND	GND
26	GND	GND
27	GND	GND
28	GND	GND
29	GND	GND
30	GND	GND

Terminal Number	Signal Name	Description
31	$\overline{\text{LAT}}$	Print data latch (memory storage)
32	$V_P$	Thermal head drive voltage
33	$V_P$	Thermal head drive voltage
34	$V_P$	Thermal head drive voltage
35	$V_P$	Thermal head drive power
36	$V_P$	Thermal head drive power
37	$V_P$	Thermal head drive power
38	N.C.	No connection
39	PS	Output signal of the paper sensor (Photo-transistor collector)
40	$V_{PS}$	Power supply of the paper sensor (LED anode)
41	GND	GND of the paper sensor (LED cathode, photo-transistor emitter) Platen position sensor GND
42	HS	Platen position sensor output
43	N.C.	No connection
44	FG	FG
45	FG	FG
46	N.C.	No connection
47	$\overline{\text{A}}$	Motor drive signal
48	B	Motor drive signal
49	A	Motor drive signal
50	$\overline{\text{B}}$	Motor drive signal

## **CHAPTER 5**

### **PRINT DRIVE METHOD**

#### **5.1 MOTOR AND THERMAL HEAD DRIVE METHOD**

The motor and the thermal head must be driven at the same time for printing.

The printer uses the thermal head with heat elements which size is a half-dot size of the feed direction. One dot is, therefore, composed of two of the half dots. The motor feeds the thermal paper for one dot line with four steps. In order to print one dot line, feed the thermal paper for four steps and activate the thermal head in every two step.

The example of the LTPD245 driving is shown below.

Figure 5-1 shows a timing chart for driving using six division printing.

Figure 5-2 shows a timing chart for driving using one division printing.

(The number of simultaneously activated dots should not exceed 96 dots.)

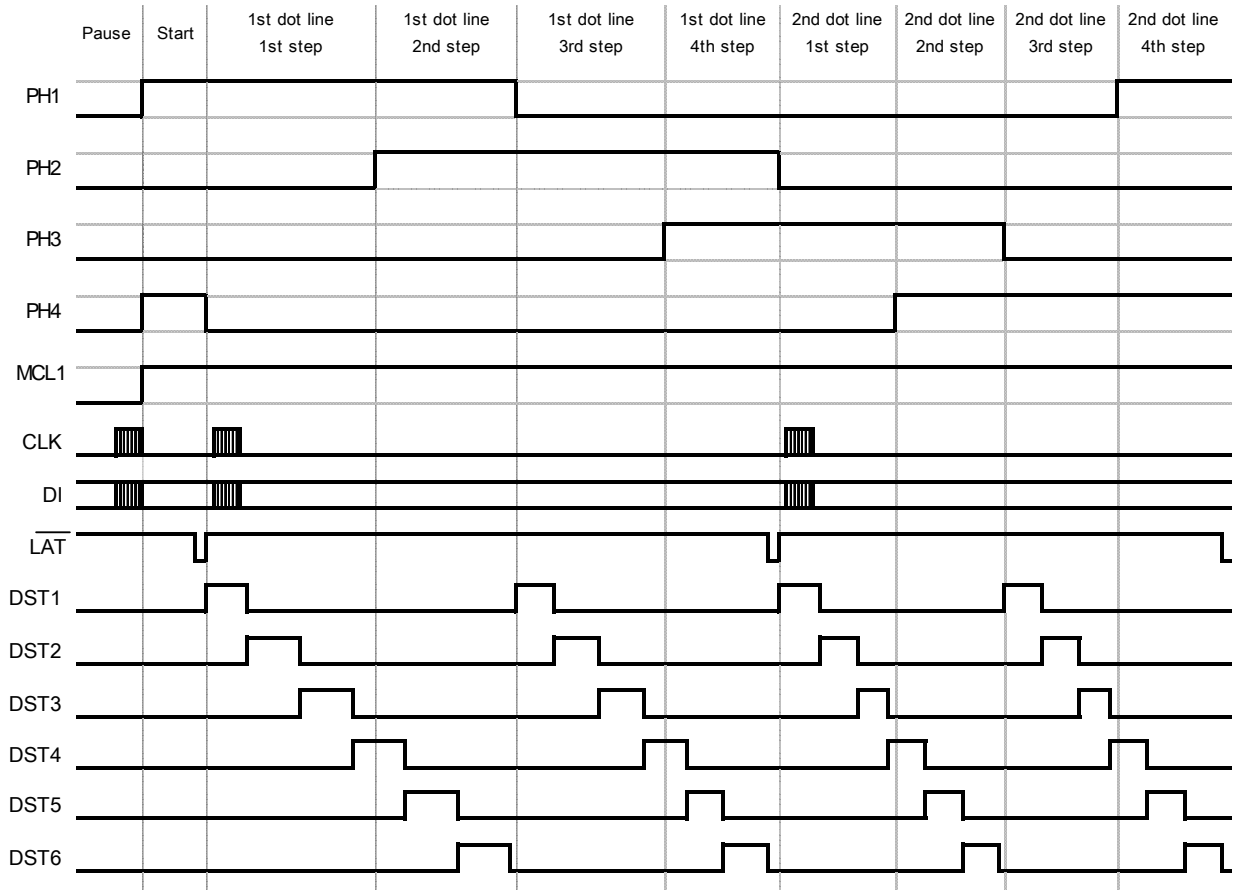

Figure 5-1 Timing Chart for Driving Using Six Divisions (LTPD245)

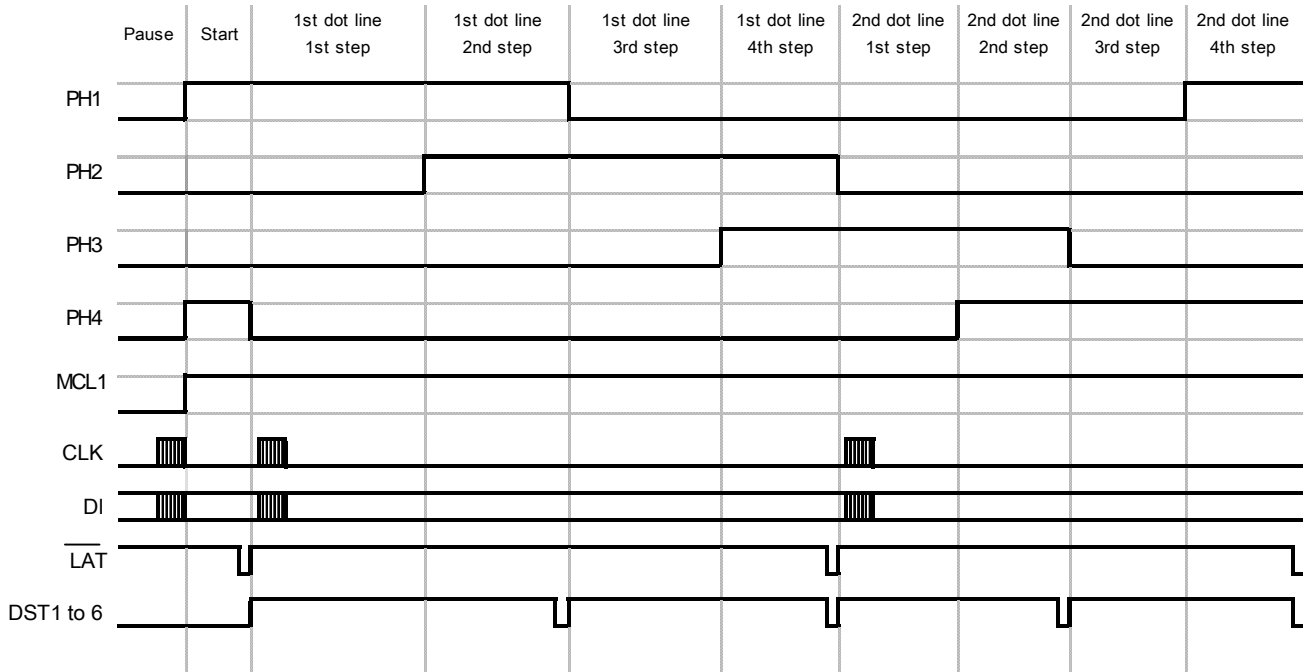

Figure 5-2 Timing Chart for Driving Using One Division (LTPD245)

The drive method using six divisions is explained below (See Figure 5-1):

(1) Pause state

Inactivate the motor and always make DST signal of the thermal head "Low". Synchronizing to the CLK signal, transfer the print data of the 1st dot line to the "SHIFT REGISTER" from the DI terminal.

(2) Start step

Excite the motor by the same phase which is output just before the motor stops.

Latch the 1st dot line data which is input at "(1) Pause state" to "LATCH REGISTER" of the thermal head by inputting the  $\overline{\text{LAT}}$  signal.

(3) 1st dot line

Drive the motor by one step.

Start activation of the thermal head through DST1 to 6 for printing 1st half dot line of the 1st dot line. At the same time, transfer the 2nd half dot line data.

The 1st step ends after the 1st step time is past even printing of the 1st half dot line has not been completed yet (without synchronizing to activation of the thermal head).

Drive the motor by one step.

The 2nd step ends after printing of the 1st half dot line is completed and the 2nd step time is past.

Drive the motor by one step.

Start activation of the thermal head through DST1 to 6 for printing the 2nd half dot line.

The 3rd step ends after the 3rd step time is past even printing of the 2nd half dot line has not been completed yet (without synchronizing to activation of the thermal head).

Drive the motor by one step.

When the printing of the 2nd half dot line is completed, latch the 2nd line dot data by  $\overline{\text{LAT}}$  signal. After latching and the 4th step time is past, the 4th step ends.

(4) Procedures that follows the 2nd dot line

Drive the motor in the same way as the way for the 1st dot line. Repeat the motor driving and thermal head activation.

## 5.2 THERMAL HEAD DIVISION DRIVE METHOD

In the thermal head of the printer, there are 6 blocks (every 64 dots) in 1 dot line for LTPD245. There are 5 blocks (4 blocks are divided every 128 dots and 1 block is divided 64dots) in 1 dot line for LTPD345. These blocks are called physical blocks. DST signal is allocated to each physical block to activate it. To drive the thermal head, physical blocks are activated in groups. The group of physical blocks is called a logical block.

The following two methods are available as thermal head division drive methods. Select one you desire.

### (1) Fixed division method

Logical blocks (physical blocks to be driven at the same time) are predetermined for the fixed division method.

In this method, high quality printing is available because the physical blocks are always driven in the same order.

The number of simultaneously activated dots of LTPD345 is available up to 96 dots, but up to 128 dots are available if the  $V_p$  is 7.9 or lower.

### (2) Dynamic division method

Logical blocks are predetermined so that number of dots of the physical block does not exceed the specified maximum number of the activating dots for every 1 dot line printing. Logical blocks are predetermined for every 1 dot line printing.

The maximum current consumption can be controlled within a constant value.

Since the order of the printing block and print speed are changed in each dot line according to the content of the print data, print quality in this method may be lower than that in fixed division method. If print quality is regarded as important, printing in fixed division method is recommended.

### **5.3 PRECAUTIONS FOR PRINT DRIVE**

- When using one division printing, a pause time between thermal head activations of the same heat element shall be secured more than 0.5ms.
- The number of the maximum thermal head division in a half dot line should be 6 or lower for LTPD245 and 9 or lower for LTPD345 to maintain print quality. The number of the simultaneously activated dots should be 96 dots or less.

## CHAPTER 6

### OUTER CASE DESIGN GUIDE

#### 6.1 SECURING THE PRINTER MAIN BODY

##### 6.1.1 How to Mount the Printer Main Body

Figure 6-1, Figure 6-2, Figure 6-3 and Figure 6-4 show dimensions for positioning and securing the printer main body.

- Holes #1 and #2 must be used for positioning the printer main body. Design bosses on the outer case to position the printer main body for the positioning holes #1 and #2. The height of the bosses on the outer case must be 1.5mm (Max.)
- Secure by screw at the U shaped screwing position c.
- Design the fixing hook to the part of a and b.
- The motors of the LTPD245B and the LTPD345B locate at the bottom of the each printer. In order to avoid interfering with the motor, the FPC and the outer case, secure enough clearance around the motor shown in Figure 6-2 and Figure 6-4.

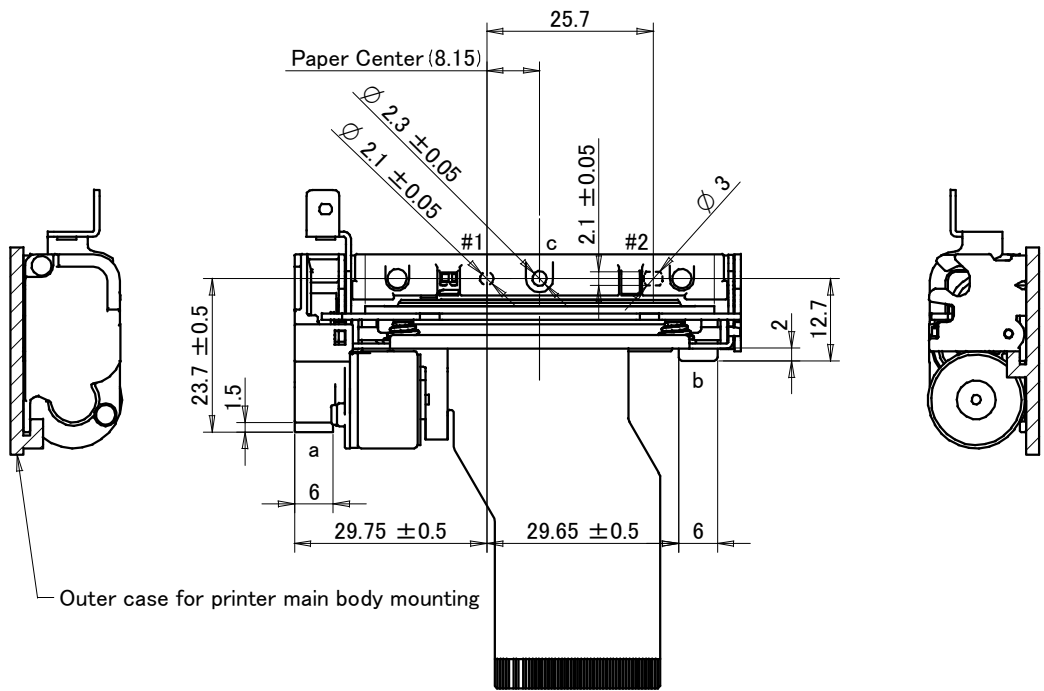

Unit : mm  
 General tolerance : ± 0.1

Figure 6-1 Dimensions for Positioning and Securing the Printer Main Body (LTPD245A)

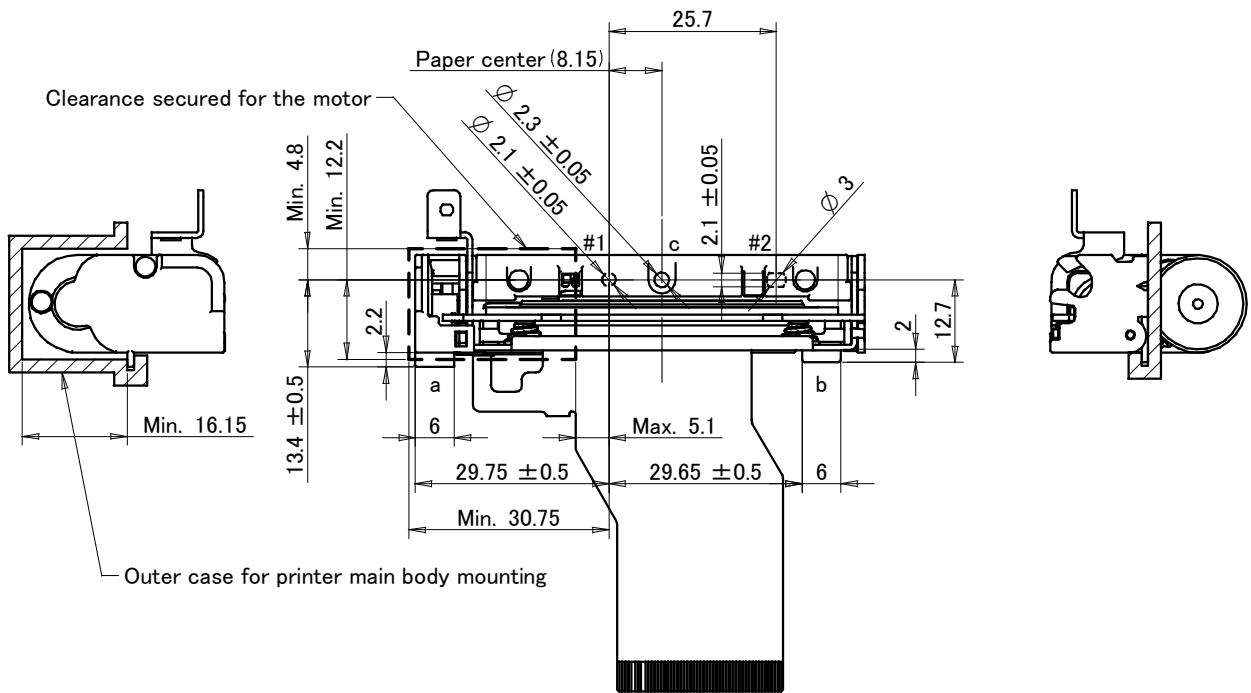

Unit : mm  
 General tolerance : ± 0.1

Figure 6-2 Dimensions for Positioning and Securing the Printer Main Body (LTPD245B)

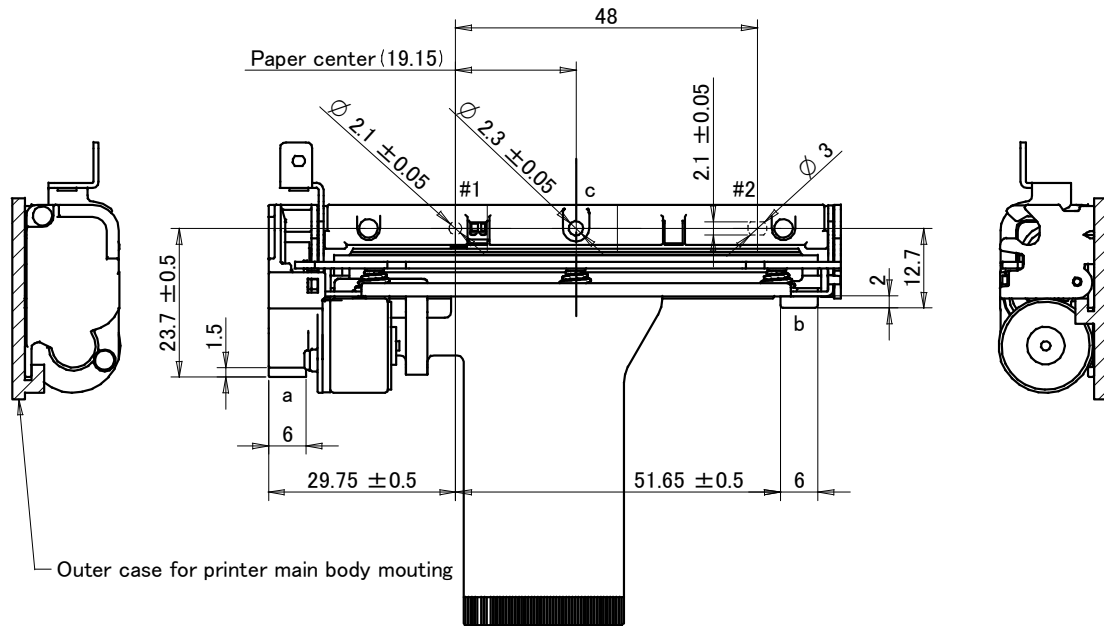

Unit : mm  
 General tolerance : ± 0.1

Figure 6-3 Dimensions for Positioning and Securing the Printer Main Body (LTPD345A)

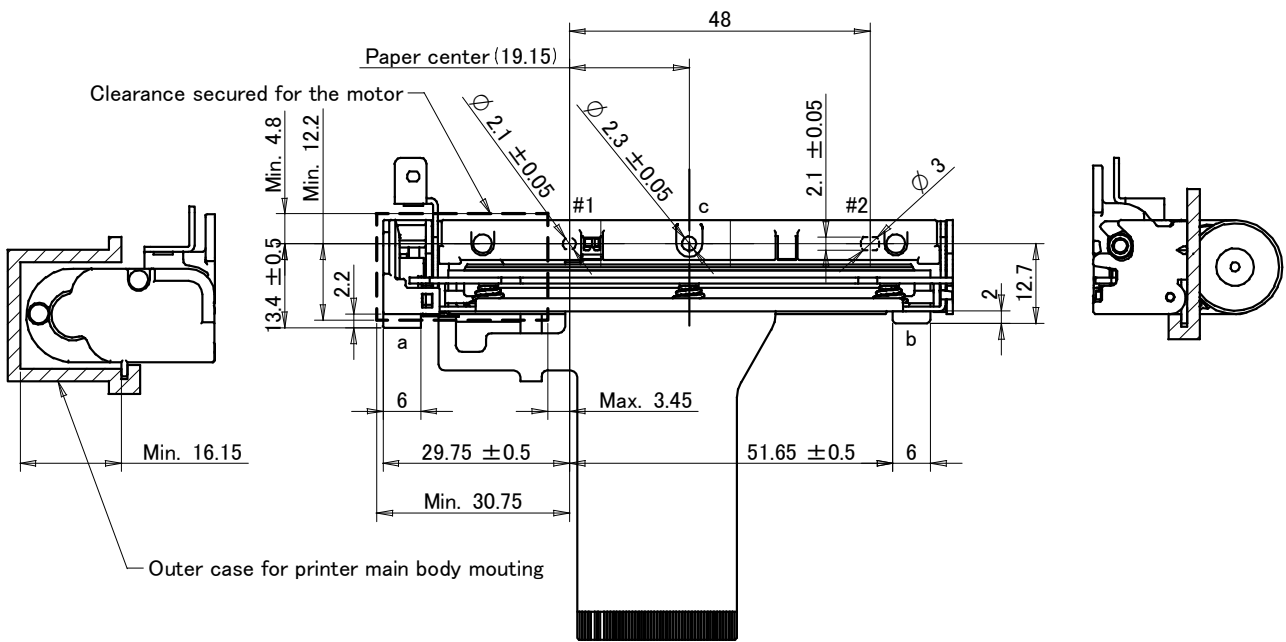

Unit : mm  
 General tolerance : ± 0.1

Figure 6-4 Dimensions for Positioning and Securing the Printer Main Body (LTPD345B)

### **6.1.2 Recommended Screws**

M2 cross-recessed pan head screw

### **6.1.3 Precautions for Securing the Printer Main Body**

- Prevent from excessive stress, deformation, and torsion for securing the printer, otherwise poor printing quality, paper skewing, paper jamming, and noise during printing may be caused.
- The printer main body to be mounted on a flat surface and prevent from vibration.
- To prevent the thermal head from being damaged by static electricity, connect the FPC terminals 44 and 45 shown in Chapter 4 to the Frame Ground (FG).
- Connect the signal ground (SG) to the frame ground (FG) using a 1M $\Omega$  resistor so that the electric potential of the signal ground (SG) of the thermal head and that of the frame ground (FG) of the printer are equal.
- Pay attention not to damage on the FPC when securing the printer main body.

## 6.2 SECURING THE PLATEN BLOCK

### 6.2.1 How to Mount the Platen Block

Figure 6-5 shows the dimensions of an engagement position of the printer main body and platen block when setting or releasing the platen block mounted on the door.

- The hole #3 and #4 must be used for positioning the platen block. Design the bosses on the door to position the platen block for the positioning holes #3 and #4. The height of the bosses on the door must be 1.5mm (Max.)
- Secure the platen block using the screw holes d and e.

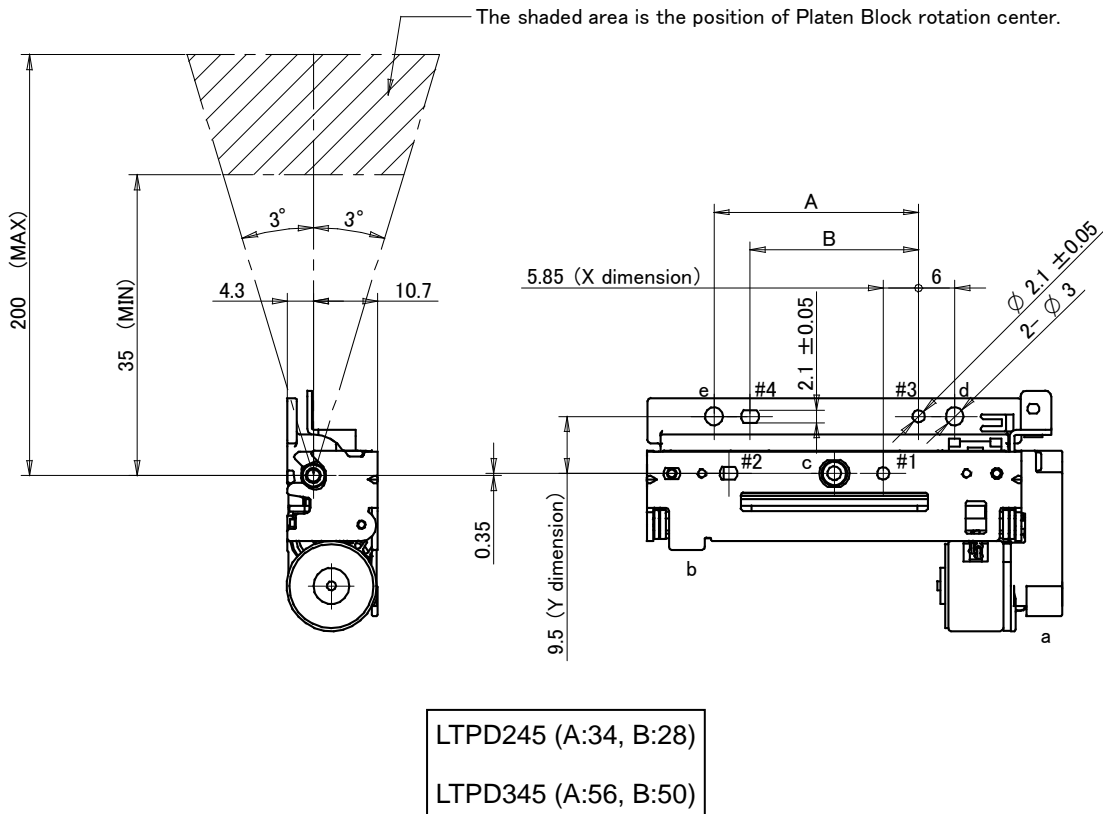

Unit : mm  
General tolerance :  $\pm 0.1$

Figure 6-5 Dimensions for Positioning and Securing the Platen Block

Table 6-1 Allowable Dimensions

Allowable X dimension	Allowable Y dimension
5.65 to 6.05	9.3 to 9.7

## 6.2.2 Recommended Screw

M2.5 cross-recessed pan head screw

## 6.2.3 Precautions for Securing the Platen Block

- Design the door on which the platen block is mounted, rotation system of the door and mounting position of the platen block on the door so that X and Y dimensions as shown in Figure 6-5 are within the allowable dimensions as shown in Table 6-1.
- It is recommended that the door and the outer case on which the printer main body is mounted are designed so that the door is guided by part of the outer case when the platen block is set into the printer main body.
- Design the rotation system of the door so that the center of the rotation is in the shaded area as shown in Figure 6-5
- Design the outer case and the door so that the platen block mounting surface to be parallel (tolerance :  $\pm 2^\circ$ ) to the printer main body mounting surface.
- Design the outer case so that the parallelism of #1-#2 and #3-#4 are 0.2 or less.
- Design the outer case so that the parallelism of the rotation center on the door to the printer main body mounting surface is 0.2 or less.
- Prevent from excessive stress, deformation, and torsion for securing the platen block.
- Design the door and the outer case strong enough to keep the allowable dimensions because stress is applied to them when setting and releasing the platen block. The rotation center of the door should be designed to fit the rotational shaft into the shaft hole so that the platen block should be stable when it is in the close state.
- If the printer main body and the platen block are not placed in proper position, the print defect and the paper jam may occur.
- A door on the outer case that holds the platen block must be set by pushing the center of the platen block. If only one end of the platen block is set, a print defect, and/or a paper jam will occur. Verify the performance with your actual device. In order to be pushed the center of the platen block to set it, put an indication to do so.
- If designing the outer case with a structure to bring the platen block up automatically using a spring property after released, make sure not to apply more than enough force to bring the platen block up. If designing a structure that the only one side of the outer case is brought up, the position relation between the printer main body with the movable blade unit and the platen block with the fixed blade unit will be improperly and will result in the print defect or the cut failure. Verify the performance with your actual device.

## **6.3 CONNECT THE PRINTER TO FRAME GROUND (FG)**

To prevent the thermal head from being damaged by static electricity, it is recommended that the printer is connected to frame ground (FG).

### **6.3.1 How to Connect the Printer to Frame Ground (FG)**

- To prevent the thermal head from being damaged by static electricity, connect the FPC terminals 44 and 45 shown in Chapter 4 to the Frame Ground (FG).
- Connect the signal ground (SG) to the frame ground (FG) using a 1M $\Omega$  resistor so that the electric potential of the signal ground (SG) of the thermal head and that of the frame ground (FG) of the printer are equal.
- If using a sheet metal material for the door, the door should also be connected to the frame ground (FG) of the interface board.

## 6.4 DESIGN THE PLATEN RELEASE LEVER

Figure 6-6 shows dimensions of the release lever and its movement when the platen release lever is released.

When designing the button or the lever that will operate simultaneously with the platen release lever, follow the precautions below.

- Design a stopper in the outer case to prevent to exceed a 11 degree range of the platen release lever's motion and to be applied excessive force (29.4N (3kg)).
- Design the button or the lever and its motion so that the platen release lever is pushed to an angle of 9 degrees of the released position.
- Design the button or the lever so that no load is constantly applied to it while the platen block is set.

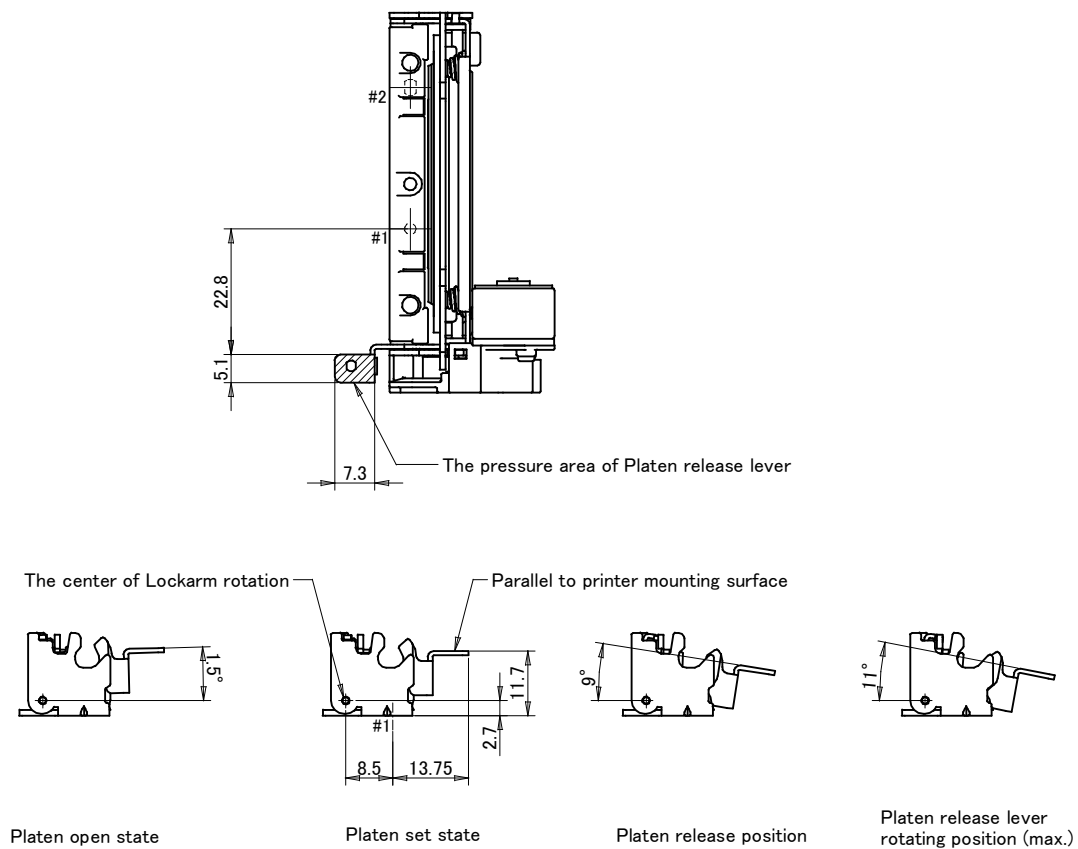

**Figure 6-6 External Dimensions and Motion of the Platen Release Lever**

## 6.5 LAYOUT OF THE PRINTER AND PAPER

The printer mechanism can be laid out as shown in Figure 6-7 according to the loading direction of the thermal paper.

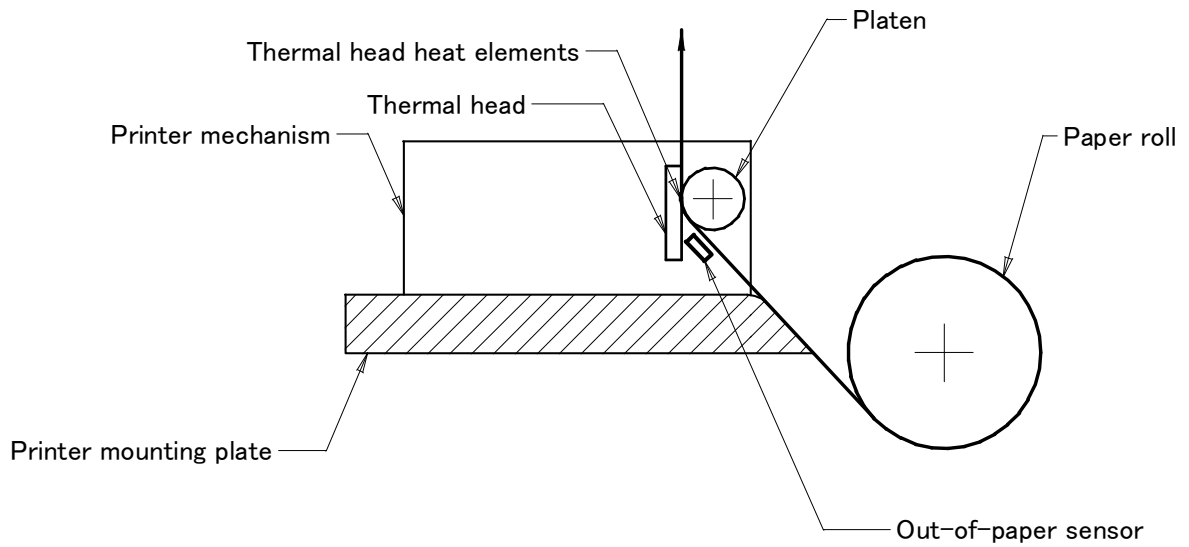

**Figure 6-7 Recommended Layout between the Printer and the Paper**

\* The thermal paper feeding distance between the out-of-paper sensor and the heat element is approximately 8.3mm

## 6.6 WHERE TO MOUNT THE PAPER HOLDER

When designing the layout of the paper holder, note the followings. The recommended configuration of the paper holder is shown in Figure 6-8.

- Design the paper holder and the paper guide so that the thermal paper will be straight to the paper inlet port without any horizontal shifting and so that the center axis of the paper roll will be parallel to the printer when using paper roll.
- Design the paper holder so that the paper feed load should be 0.49N (50gf) or less. Be aware that the printing problem and paper feed problem may occur in the following case even if it is below 0.49N. Design the paper holder so as not to make these conditions and verify the performance with your actual device.

ex)

In case that the paper roll wobbles in the paper holder.

In case that tension of the thermal paper between the paper roll and the printer changes rapidly.

In addition, do not use following types of thermal paper:

Expanded paper roll

Deformed paper roll

Roll core is sticking out.

Width of the paper roll is out of spec

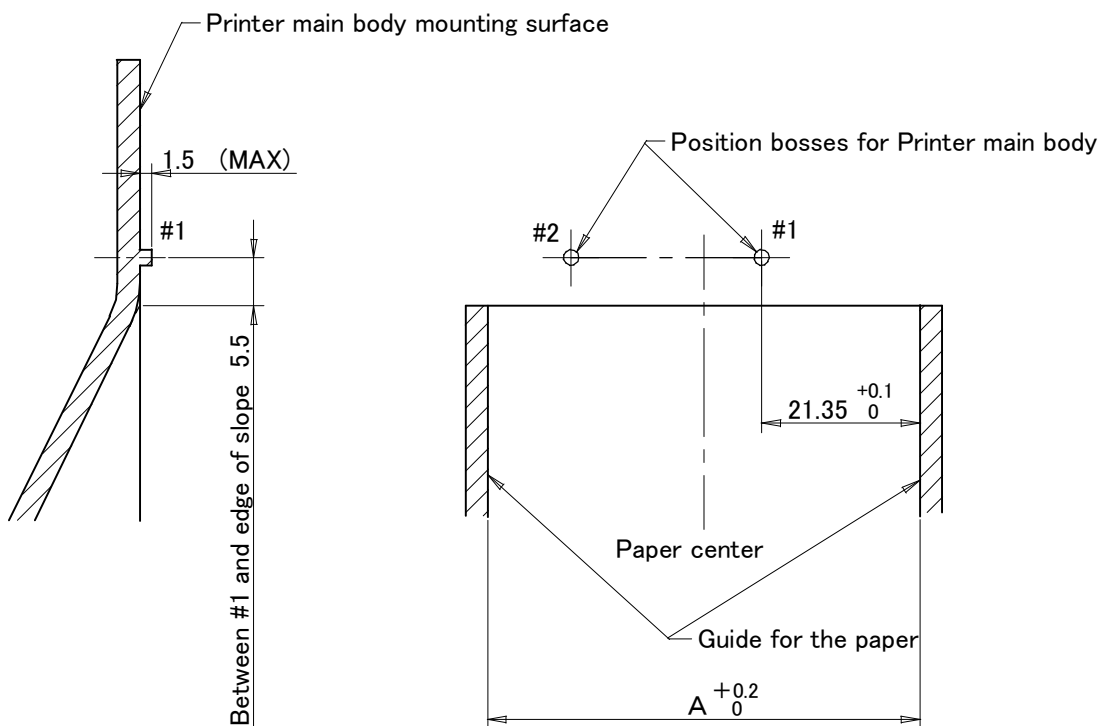

Unit : mm  
General tolerance :  $\pm 0.1$

LTPD245 (A:59)  
LTPD345 (A:81)

**Figure 6-8 Recommended Paper Holder Dimensions**

## 6.7 DESIGN PAPER EXIT

### 6.7.1 Design the Shape of the Paper Exit

When designing the shape of the paper exit, note the followings.

- Design the shape of the paper exit so that stress is not applied to the thermal paper that comes out.
- Design the paper exit of the outer case and the door so that the thermal paper coming out angle must be within of 50° to 85° as shown in Figure 6-9. The paper exit design should not interfere with the thermal paper coming out. Design the paper exit not to change thermal paper coming out direction and not interfere with paper feeding.

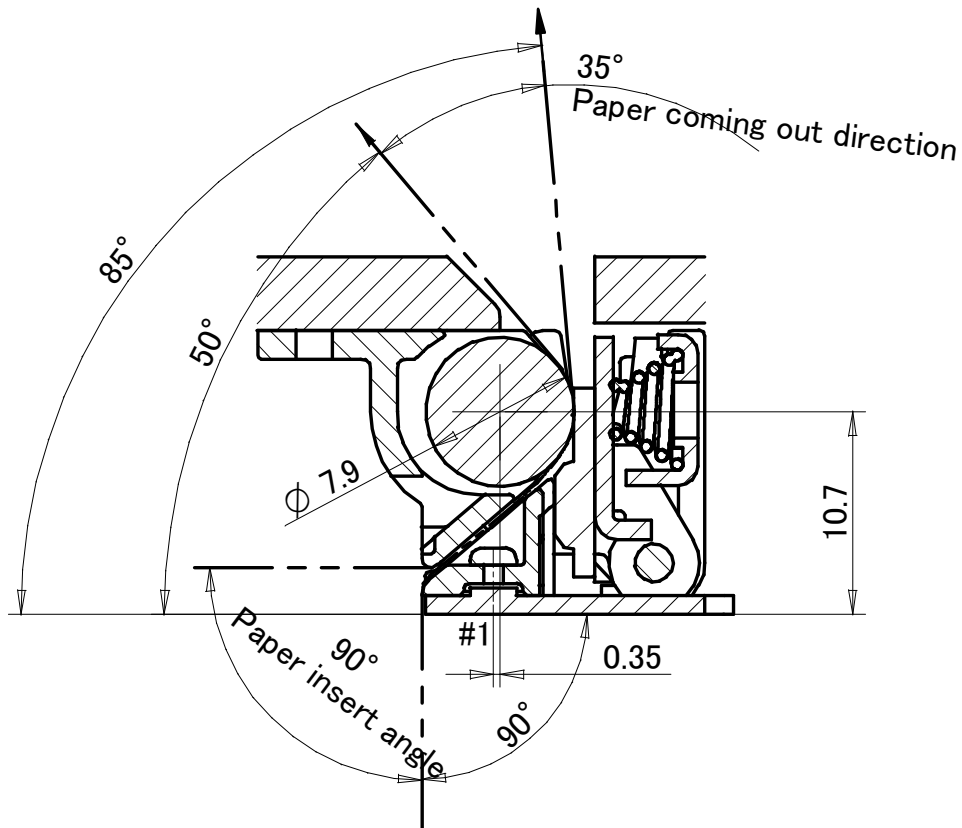

Unit : mm  
General tolerance :  $\pm 0.1$

Figure 6-9 Paper Path

### 6.7.2 Design the Paper Cutter

- Design paper cutter mounting position so the edge of the cutter blade does not touch with a platen block when the platen block is set and released.
- Use a well-cut cutter so that the thermal paper can be cut with less force than paper holding force.
- Design the blade edge of the cutter as shown in the right figure of Figure 6-10 so that the blade edge can guide the thermal paper edge after cutting. If designing the blade edge as shown in the left figure, the paper edge may be caught by the blade edge and result in the thermal paper edge to be caught inside of the cutter.
- Set the paper cutter to a position that allows to feed the paper backwards up to 9mm.

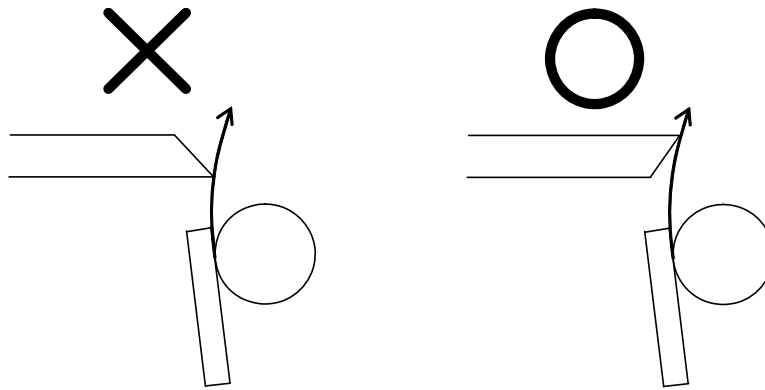

Figure 6-10 Blade Edge

## 6.8 PRECAUTIONS FOR DESIGNING THE OUTER CASE

- The thermal paper with a small winding diameter may cause the paper jam in the printer main body and a gap between the printer mechanism and the outer case. If using such a thermal paper with the small diameter, verify the performance with your actual device.
- Design the outer case to ensure enough space to allow the users to handle the platen release lever easily with fingers.  
See Chapter 8 “PROCEDURES for INSTALLING/UNINSTALLING THERMAL PAPER” for specific procedures. Also, see 6.4 “DESIGN THE PLATEN RELEASE LEVER” for its motion.
- Design the outer case so that it and parts for the outer case will not apply any load to the printer main body and the platen block. The load may affect printing, and also may damage the printer mechanism. Secure 1.0mm (min.) space between the printer main body and platen block and the outer case.

## **CHAPTER 7**

### **EXTERNAL DIMENSIONS**

Figure 7-1 shows external dimensions of the platen block for LTPD245 and Figure 7-2 and Figure 7-3 show external dimensions of the printer LTPD245A and LTPD245B.

Figure 7-4 shows external dimensions of the platen block for LTPD345 and Figure 7-5 and Figure 7-6 show external dimensions of the printer LTPD345A and LTPD345B.

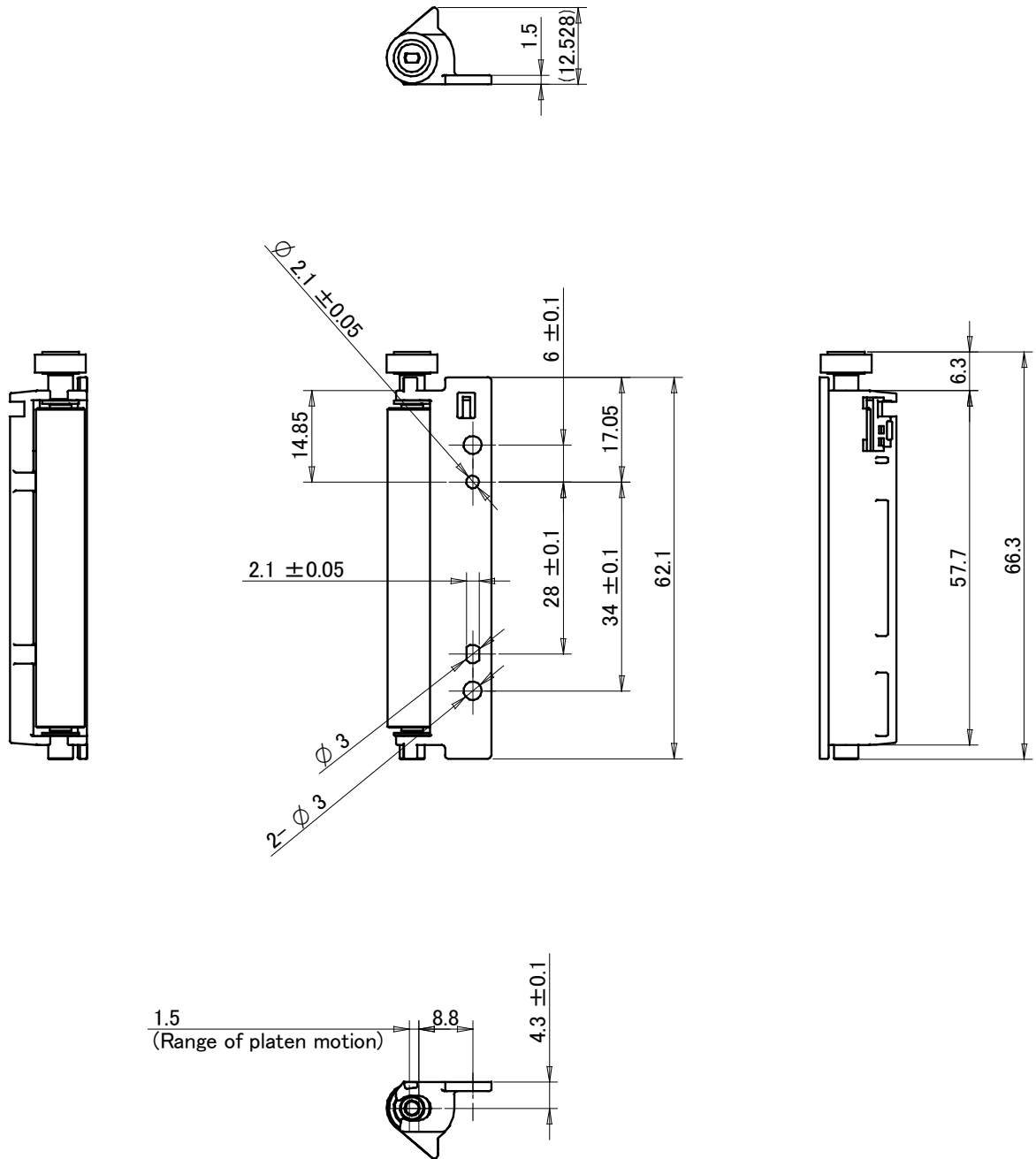

Unit : mm  
 General tolerance :  $\pm 0.5$

Figure 7-1 External Dimensions of the Platen Block (LTPD245)

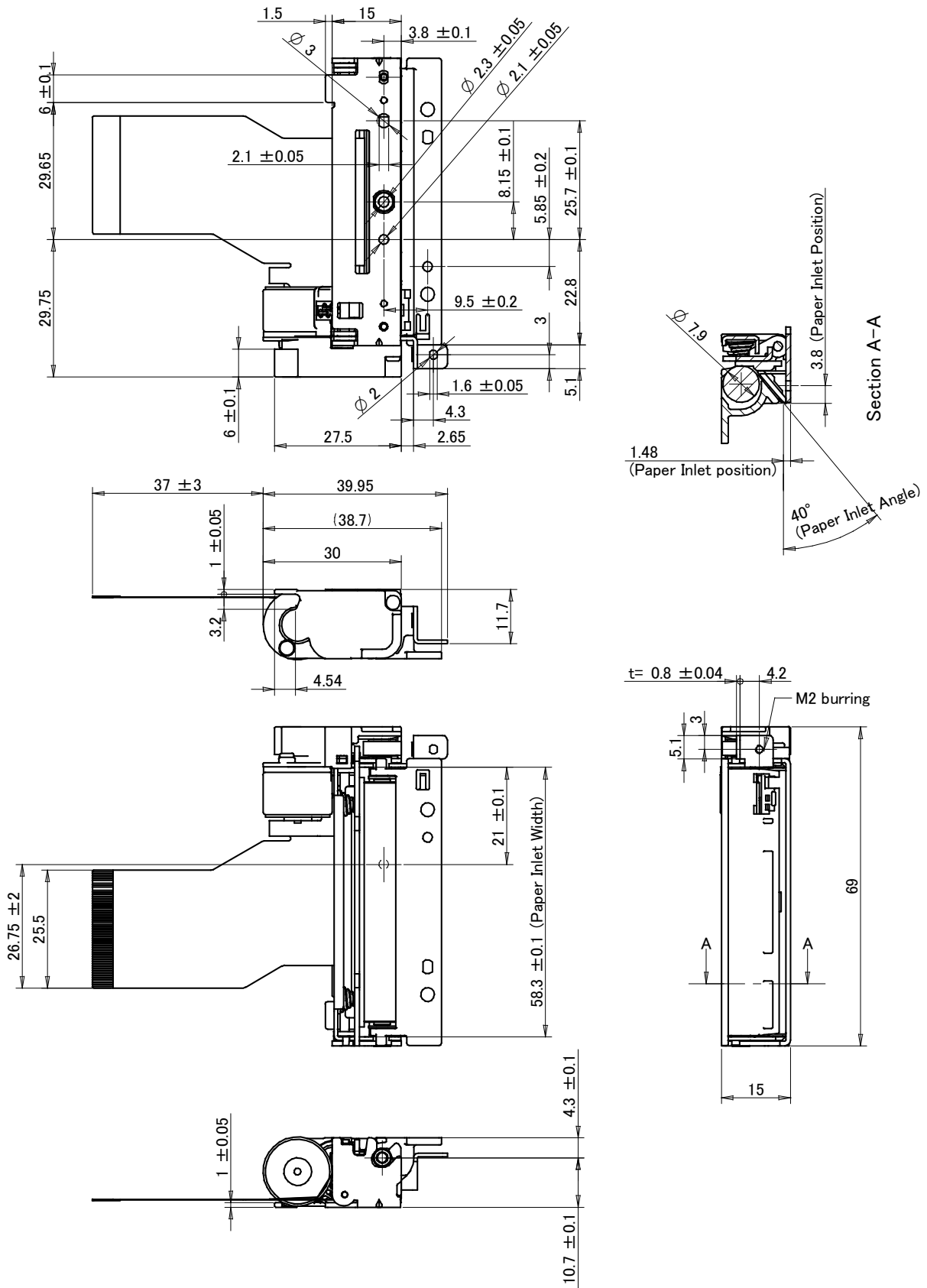

Unit : mm  
 General tolerance : ±0.5

Figure 7-2 External Dimensions of the Printer (LTPD245A)



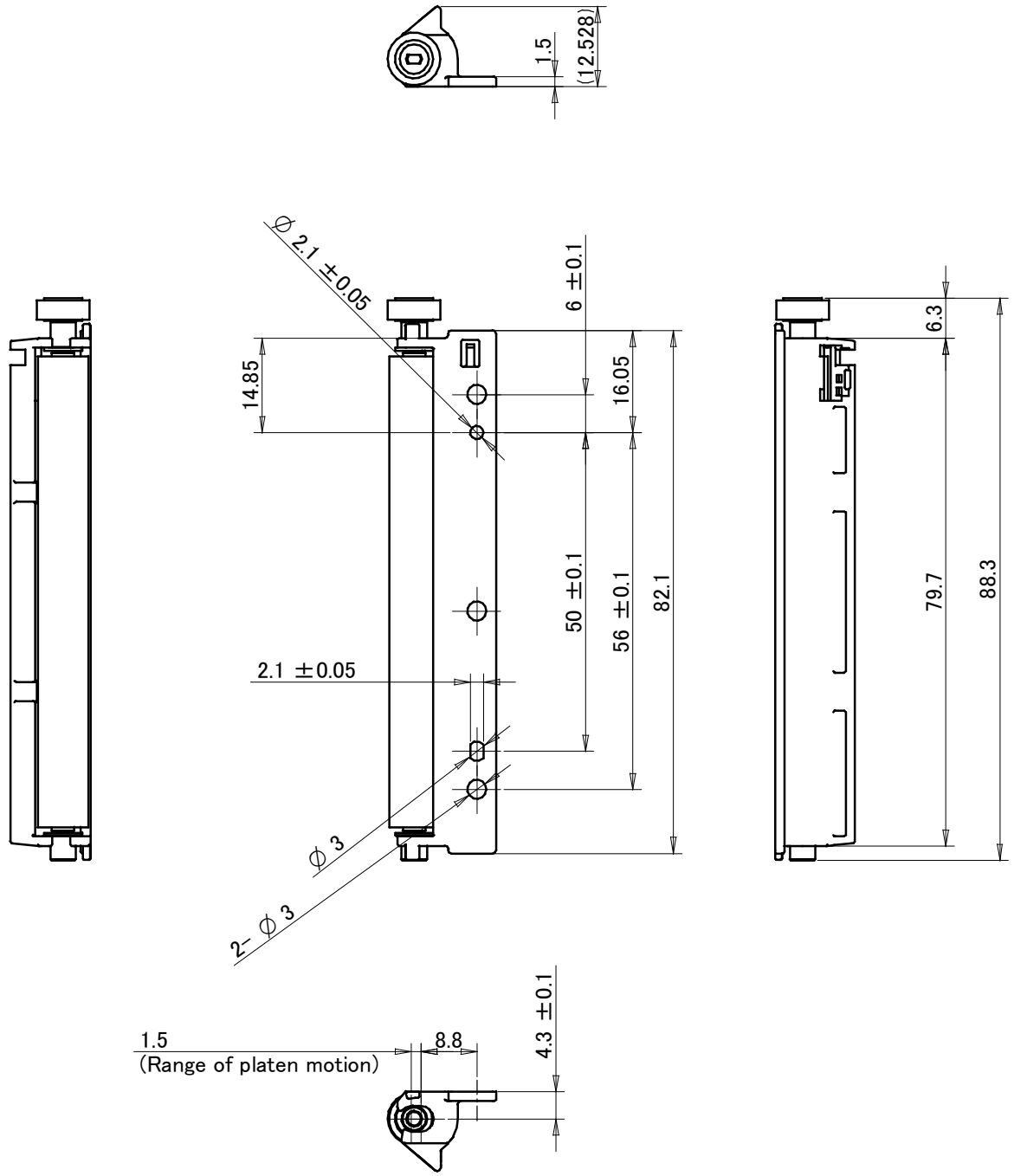

Unit : mm  
 General tolerance : ± 0.5

Figure 7-4 External Dimensions of the Platen Block (LTPD345)

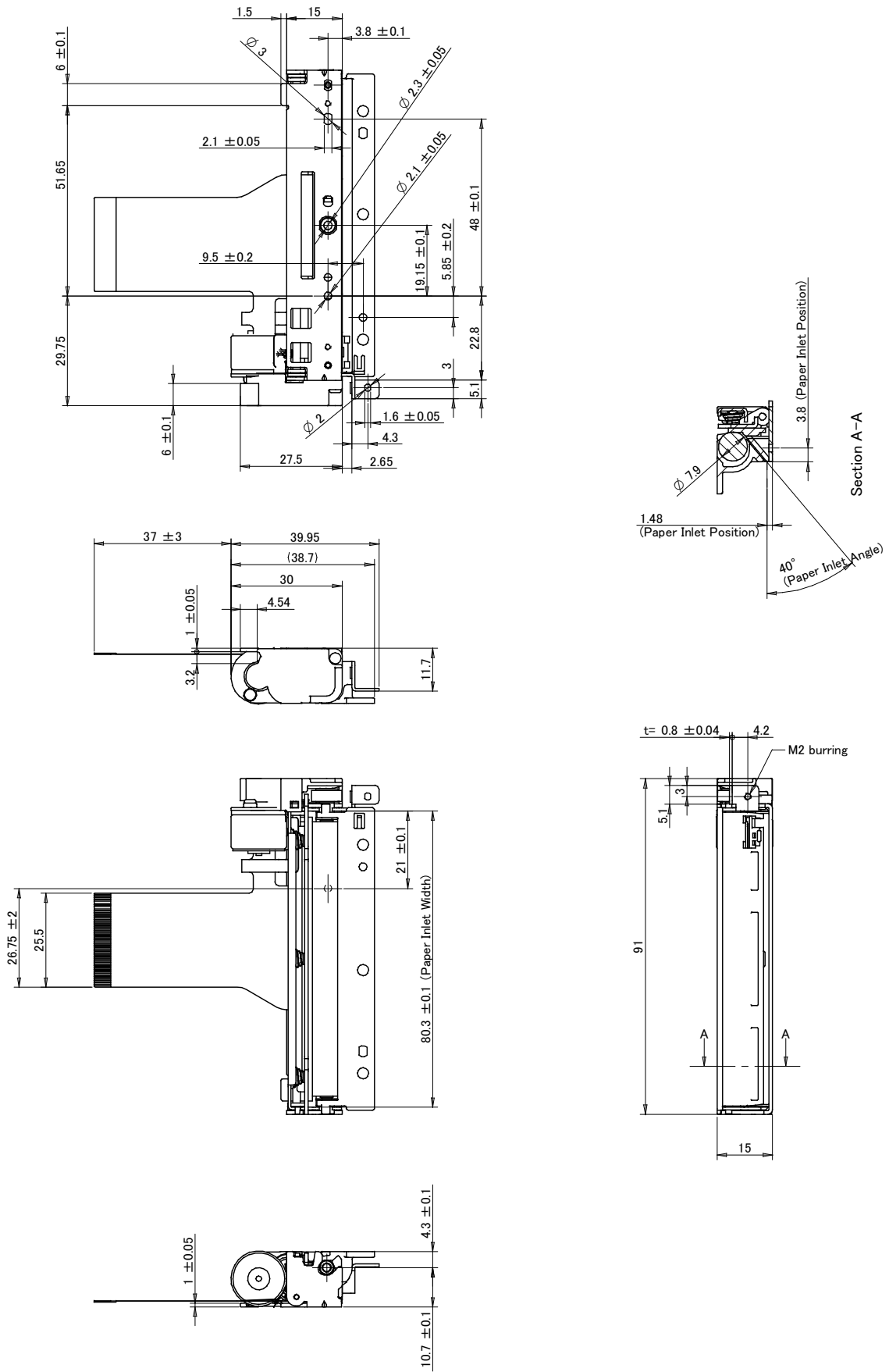

Unit : mm  
 General tolerance : ± 0.5

Figure 7-5 External Dimensions of the Printer (LTPD345A)

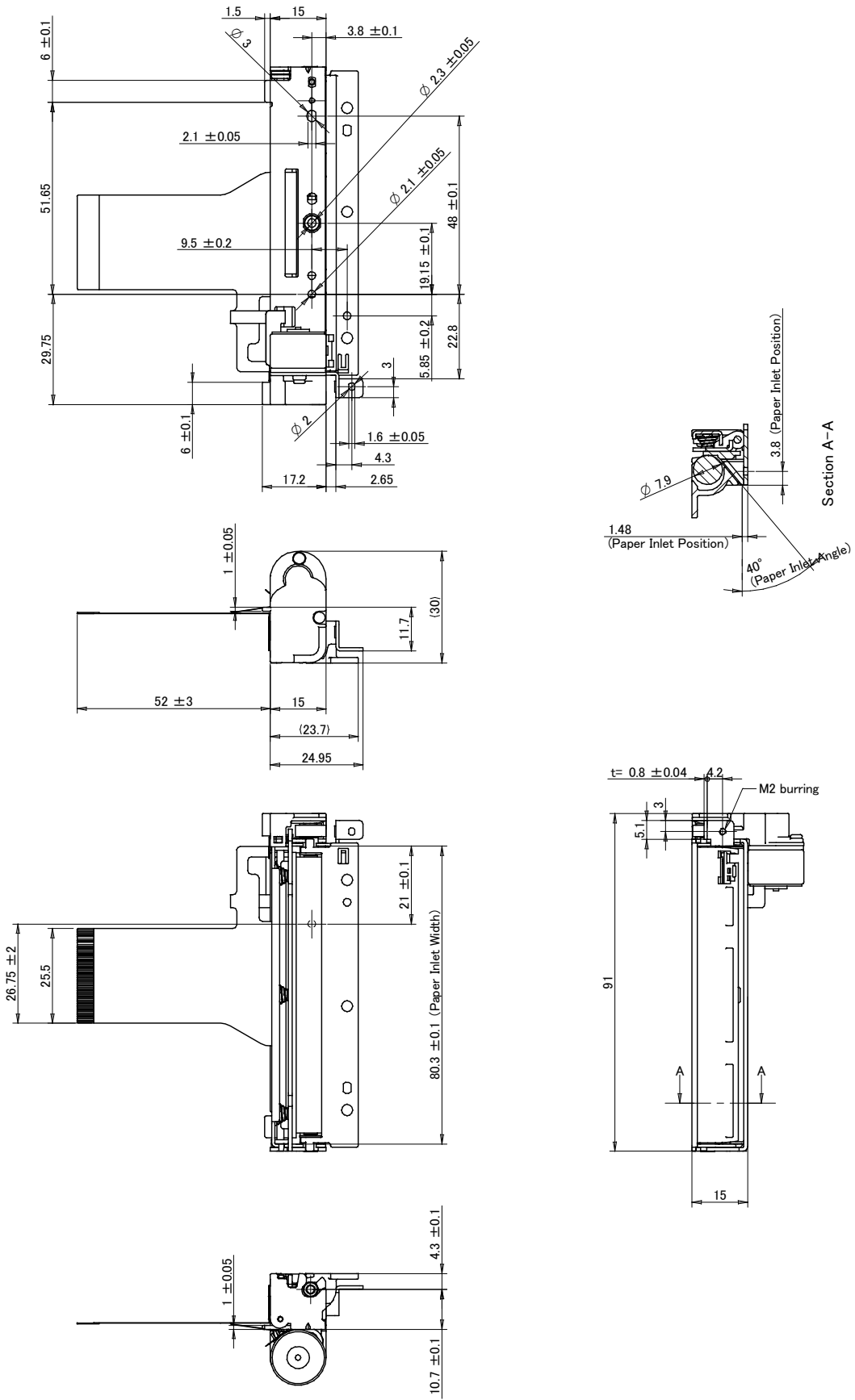

Unit : mm  
 General tolerance :  $\pm 0.5$

Figure 7-6 External Dimensions of the Printer (LTPD345B)

## CHAPTER 8 HANDLING METHOD

### 8.1 PROCEDURES FOR INSTALLING/UNINSTALLING THE THERMAL PAPER

#### 8.1.1 Procedures for Installing/Uninstalling the Thermal paper

##### ① Installing the thermal paper

- Push the platen release lever in the direction of the arrow in the Figure 8-1.

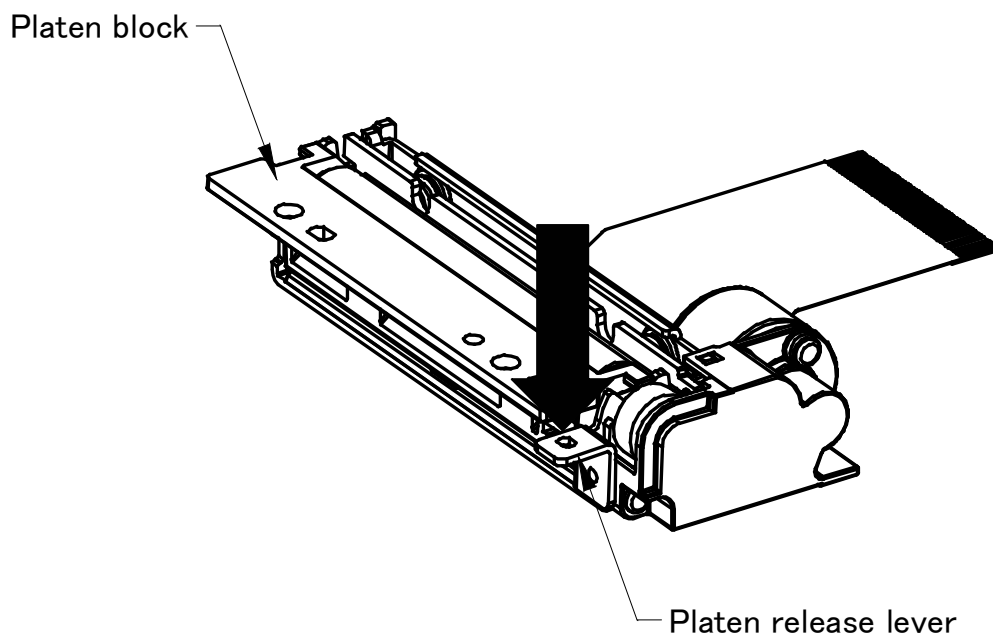

**Figure 8-1 Loading the Thermal Paper (1)**

- Pull up the platen block after making sure that the platen block is released from the printer main body. (Open state)
- Set the thermal paper straight to the printer and leave at least 5cm of the thermal paper come out from the printer in the Figure 8-2.

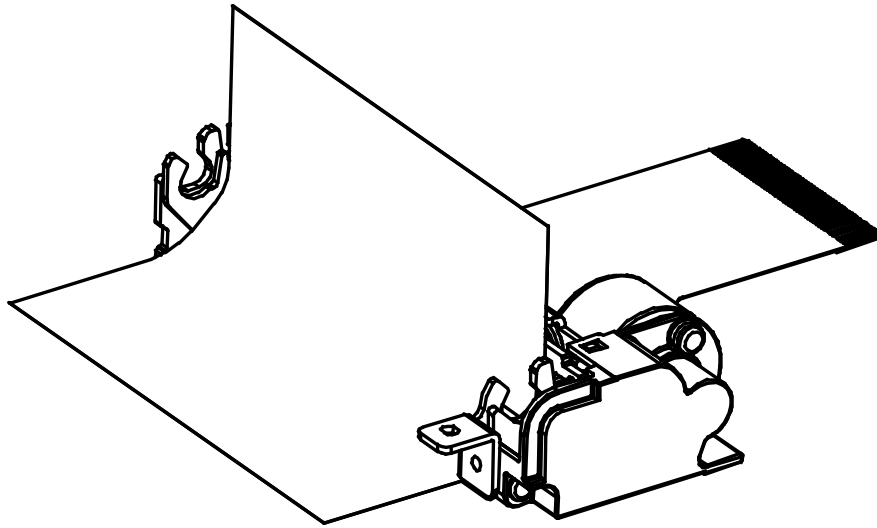

**Figure 8-2 Loading the Thermal Paper (2)**

- Set the platen block after making sure that the thermal paper is set straight. (Close state)
- ② Uninstall the thermal paper
- Uninstall the thermal paper in the same manner for installing the thermal paper.
- ③ Clearing a paper jam
- Uninstall the thermal paper in the same manner for installing the thermal paper.

### **8.1.2 Precautions for Installing the Thermal Paper**

- Install the thermal paper with the platen block released. Automatic loading is not allowed.
- Set the thermal paper straight to the printer and leave at least 5 cm of the thermal paper come out from the printer.
- When setting the platen block, the reduction gear may interfere with the platen gear and may cause the platen block to not be set. In such a case, release the platen block and set it again.
- If the thermal paper is skewed, feed the thermal paper until the thermal paper becomes straight or install the thermal paper again.
- Remove the jamming paper with the platen block released. Do not pull the thermal paper by force because severe damages may occur.

## 8.2 PRECAUTIONS FOR CLEANING THE THERMAL HEAD

If the surface of the thermal head exposed to dirt, ensure to clean the thermal head to avoid a print defect.

### 8.2.1 Procedures for Cleaning the Thermal Head

- Turn off the power before cleaning.
- Push the platen release lever to the direction of the arrow in the Figure 8-3. Pull up the platen block after making sure that the platen block is released from the printer main body.
- Clean the heat element shown in Figure 8-3 using a cotton swab dipped in ethyl alcohol or isopropyl alcohol.
- Set the platen block after the alcohol has dried completely.

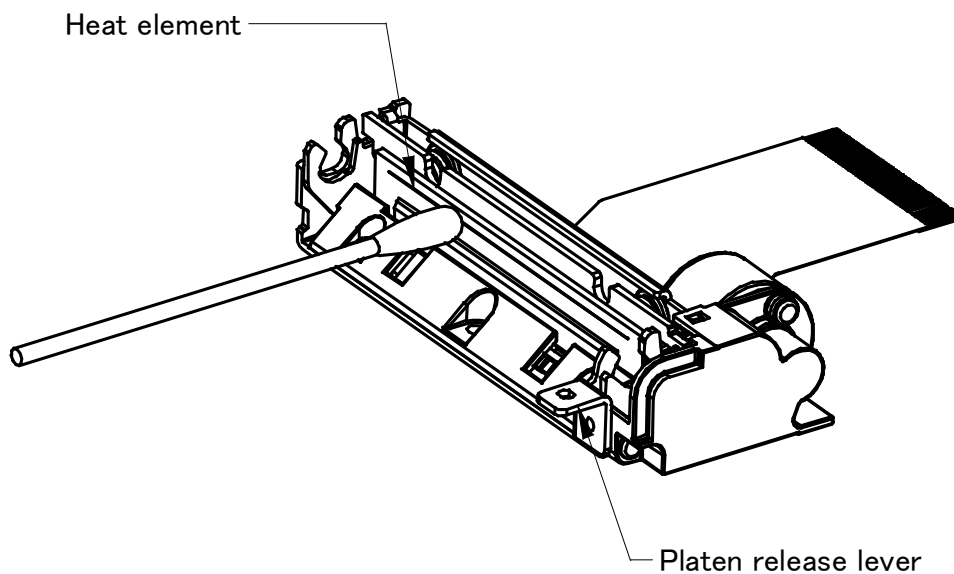

**Figure 8-3** Cleaning Position of the Thermal Head

### 8.2.2 Precautions for Cleaning the Thermal Head

- Do not clean the thermal head immediately after printing because the temperature of the thermal head and its peripherals rises very high during and immediately after printing.
- Clean the thermal head with the platen block released.
- Do not use sandpaper, a cutter knife and etc. for cleaning. They will damage the heat element.