

SII 

CAPD245
AUTOCUTTER INTEGRATED
THERMAL PRINTER MECHANISM
TECHNICAL REFERENCE

U00114572200

Seiko Instruments Inc.

CAPD245 AUTOCUTTER INTEGRATED THERMAL PRINTER MECHANISM TECHNICAL REFERENCE

Document Number U00114572200

First Edition December 2008

Copyright © 2008 by Seiko Instruments Inc.
All rights reserved.

Seiko Instruments Inc. (hereinafter referred to as "SII") has prepared this technical reference for use by SII personnel, licensees, and customers. The information contained herein is the property of SII and shall not be reproduced in whole or in part without the prior written approval of SII.

SII reserves the right to make changes without notice to the specifications and materials contained herein and shall not be responsible for any damages (including consequential) caused by reliance on the materials presented, including but not limited to typographical, arithmetic, or listing errors.

SII ● is a trademark of Seiko Instruments Inc.

PREFACE

This technical reference describes the specifications and basic operating procedures for the CAPD245 autocutter integrated thermal printer mechanism (hereinafter referred to as “printer”).

The printer has the following model.

- CAPD245A-E

Chapter 1 “Precautions” describes safety, design, and handling precautions. Read it thoroughly before designing so that you are able to use the product properly.

SII has not investigated the intellectual property rights of the sample circuits included in this technical reference. Fully investigate the intellectual property rights of these circuits before using.

The printer complies with EU RoHS Directive (2002/95/EC)

The printer contains “Pb”, the details are described below.

- a particular free-cutting steel parts, a particular component in glass of the electronic parts

*Lead-containing items listed above are exempt from RoHS (2002/95/EC).

TABLE OF CONTENTS

CHAPTER 1 PRECAUTIONS

1.1	SAFETY PRECAUTIONS.....	1-2
1.2	DESIGN AND HANDLING PRECAUTIONS.....	1-3
1.2.1	Design Precautions.....	1-3
1.2.2	Handling Precautions.....	1-5
1.2.3	Precautions on Discarding.....	1-6

CHAPTER 2 FEATURES

CHAPTER 3 SPECIFICATIONS

3.1	GENERAL SPECIFICATIONS.....	3-1
3.2	PRINT CONFIGURATION.....	3-4
3.3	STEP MOTOR (PRINTER DRIVE MOTOR).....	3-5
3.3.1	General Specifications.....	3-5
3.3.2	Sample Drive Circuit.....	3-6
3.3.3	Excitation Sequence.....	3-8
3.3.4	Printer Drive Motor Start/Stop Method.....	3-9
3.3.5	Printer Drive Motor Drive Method.....	3-10
3.3.6	Motor Drive Precautions.....	3-16
3.4	THERMAL HEAD.....	3-17
3.4.1	Structure of the Thermal Head.....	3-17
3.4.2	Connection of Transfer Data and Print Position.....	3-18
3.4.3	Electrical Characteristics of Thermal Head.....	3-19
3.4.4	Timing Chart.....	3-20
3.4.5	Thermal Head Heat Element Resistance.....	3-20
3.4.6	Maximum Current Consumption.....	3-20

3.5	CONTROLLING THE ACTIVATION PULSE WIDTH FOR THERMALHEAD	3-21
3.5.1	Calculation of Activation Pulse Width	3-21
3.5.2	Calculation of Printing Energy.....	3-22
3.5.3	Adjustment of Thermal Head Resistance	3-23
3.5.4	Adjustment of Thermal Head Drive Voltage	3-23
3.5.5	Setting of Activation Pause Time	3-23
3.5.6	Adjustment by Thermal Head Activation Pulse Cycle.....	3-23
3.5.7	Calculation Sample for the Activation Pulse Width.....	3-24
3.5.8	Temperature Characteristics of the Thermistor	3-27
3.5.9	Detecting Abnormal Temperature of the Thermal Head.....	3-29
3.6	THERMAL PAPER CUTTING CONDITIONS.....	3-30
3.7	STEP MOTOR (AUTOCUTTER DRIVE MOTOR)	3-31
3.7.1	General Specifications	3-31
3.7.2	Sample Drive Circuit	3-31
3.7.3	Excitation Sequence	3-33
3.7.4	Autocutter Drive Motor Start/Stop Method.....	3-34
3.7.5	Autocutter Drive Motor Drive Method.....	3-35
3.7.6	Precaution of the Autocutter Drive Motor.....	3-35
3.8	OUT-OF-PAPER SENSOR	3-36
3.9	PLATEN POSITION SENSOR	3-37
3.9.1	General Specifications	3-37
3.9.2	Platen Position Sensor Precautions	3-38
3.10	CUTTER HOME POSITION SENSOR	3-39

CHAPTER 4 CONNECTING TERMINALS

4.1	RECOMMENDED CONNECTOR FOR EXTERNAL CIRCUITS.....	4-1
4.2	PRINTER CONNECTING TERMINALS	4-1
4.3	AUTOCUTTER CONNECTING TERMINALS	4-4

CHAPTER 5 DRIVE METHOD

5.1	PRINT DRIVE METHOD.....	5-1
5.1.1	Printer Drive Motor and Thermal Head Drive Method	5-1
5.1.2	Thermal Head Division Drive Method	5-4
5.1.3	Precautions for Print Drive	5-4
5.2	AUTOCUTTER DRIVE METHOD.....	5-5
5.2.1	Timing Chart for Autocutter Drive	5-5
5.2.2	Flow Chart for Autocutter Drive.....	5-6
5.2.3	Precautions for Using the Autocutter	5-8
5.3	AUTO-LOADING METHOD FOR THE THERMAL PAPER	5-9

CHAPTER 6 OUTER CASE DESIGN GUIDE

6.1	MOUNTING POSITION	6-1
6.2	SECURING THE PRINTER MAIN BODY	6-2
6.2.1	How to Mount the Printer Main Body	6-2
6.2.2	Recommended Screws.....	6-4
6.2.3	Precautions for Securing the Printer Main Body.....	6-4
6.3	SECURING THE PLATEN BLOCK	6-5
6.3.1	How to Mount the Platen Block.....	6-5
6.3.2	Recommended Screw.....	6-6
6.3.3	Precautions for Securing the Platen Block	6-7
6.4	CONNECT TO THE FRAME GROUND (FG)	6-8
6.4.1	How to Connect to the Frame Ground (FG)	6-8
6.5	DESIGN THE PLATEN RELEASE LEVER	6-9
6.6	LAYOUT OF THE PRINTER MECHANISM AND THE THERMAL PAPER.....	6-11
6.7	WHERE TO MOUNT THE PAPER HOLDER.....	6-12
6.8	DESIGN THE PAPER EXIT.....	6-13
6.8.1	Design the Shape of the Paper Exit.....	6-13
6.9	PRECAUTIONS FOR DESIGNING THE OUTER CASE	6-15

CHAPTER 7 EXTERNAL DIMENSIONS

CHAPTER 8 HANDLING METHOD

8.1	INSTALLING/UNINSTALLING THE THERMAL PAPER.....	8-1
8.1.1	Procedures for Installing the Thermal Paper	8-1
8.1.2	Procedures for Uninstalling the Thermal Paper.....	8-4
8.1.3	Procedures for Removing the Paper Jam.....	8-4
8.1.4	Procedures for Releasing when the Movable Blade is Stopped	8-4
8.1.5	Precautions for Installing/Uninstalling the Thermal Paper.....	8-5
8.2	CLEANING THE THERMAL HEAD	8-6
8.2.1	Procedures for Cleaning the Thermal Head.....	8-6
8.2.2	Precautions for Cleaning the Thermal Head.....	8-6

FIGURES

3-1	Dot Pitch.....	3-4
3-2	Print Area	3-4
3-3a	Sample Drive Circuit 1	3-6
3-3b	Sample Drive Circuit 2	3-7
3-4	Input Voltage Waveforms for the Sample Drive Circuit	3-8
3-5	Printer Drive Motor Start/Stop Timing Chart	3-9
3-6	Thermal Head Block Diagram (CAPD245)	3-17
3-7	Transfer Data and Print Position (CAPD245)	3-18
3-8	Thermal Head Drive Timing Chart	3-20
3-9	Temperature Characteristics of the Thermistor	3-27
3-10	Thermal Paper Cut Condition.....	3-30
3-11a	Sample Drive Circuit 1	3-31
3-11b	Sample Drive Circuit 2	3-32
3-12a	Input Voltage Waveforms for the Sample Drive Circuit (Outward)	3-33
3-12b	Input Voltage Waveforms for the Sample Drive Circuit (Homeward)	3-33
3-13	Autocutter Drive Motor Start/Stop Timing Chart	3-34
3-14	Sample External Circuit of the Out-of-paper Sensor	3-36
3-15	Sample External Circuit of the Platen Position Sensor.....	3-37
3-16	Sample External Circuit of the Cutter Home Position Sensor.....	3-39
4-1	Printer Connecting Terminals.....	4-1
4-2	Autocutter Connecting Terminals.....	4-4
5-1	Timing Chart for Using Fixed Six Divisions Printing (CAPD245)	5-2
5-2	Timing Chart for Using Batch Printing (CAPD245)	5-2
5-3	Timing Chart for Autocutter Drive (CAPD245)	5-5
5-4	Autocutter Flow Chart : Initializing.....	5-6
5-5	Autocutter Flow Chart : Cut Performance	5-7
5-6	Effective Use of the Cutting Thermal Paper.....	5-8
5-7	Flow Chart for Auto-loading the Thermal Paper	5-9

6-1	Mounting Position.....	6-1
6-2	Dimensions for Positioning and Securing the Printer Main Body	6-2
6-3	Sample for Positioning and Securing the Printer Main Body (1) (Fixed by the Mounting Part a, b and b')	6-3
6-4	Sample for Positioning and Securing the Printer Main Body (2) (Fixed by the Mounting Part a, c and c')	6-3
6-5	Sample for Positioning and Securing the Printer Main Body (3) (Fixed by the Mounting Part a, c and c')	6-3
6-6	Dimensions for Positioning and Securing the Platen Block.....	6-5
6-7	Working Area of the Platen Release Lever.....	6-9
6-8	External Dimensions of the Platen Release Lever	6-9
6-9	Design Example of the External Lever.....	6-10
6-10	Recommended Layout between the Printer Mechanism and the Thermal Paper.....	6-11
6-11	Recommended Paper Holder Dimensions	6-12
6-12a	Recommended Sample of the Paper Exit (Printer main body side)	6-14
6-12b	Recommended Sample of the Paper Exit (Platen block side).....	6-14
7-1	External Dimensions (CAPD245).....	7-2
8-1a	Installing the Thermal Paper by the Easy Operation	8-2
8-1b	Installing the Thermal Paper by the Easy Operation	8-2
8-1c	Installing the Thermal Paper by the Easy Operation	8-2
8-2	Shape of the Thermal Paper Edge	8-3
8-3	Installing the Thermal Paper by the Auto-loading	8-3
8-4	Cleaning Position of the Thermal Head	8-6

TABLES

3-1	General Specifications	3-1
3-2	General Specifications of the Step Motor	3-5
3-3	Excitation Sequence	3-8
3-4	Maximum Motor Drive Pulse Rate	3-10
3-5	Acceleration Steps (CAPD245).....	3-12
3-6	Maximum Continuous Drive Time / Length (1): Temperature Rise 50°C	3-13
3-7	Drive Rate: Temperature Rise 50°C	3-14
3-8	Maximum Continuous Drive Time / Length (2): Temperature Rise 75°C (Reference) ...	3-15
3-9	DST Terminals and Activated Heating Elements (CAPD245)	3-18
3-10	Electrical Characteristics of Thermal Head (CAPD245)	3-19
3-11	Thermal Head Heat Element Resistance.....	3-20
3-12	Standard Printing Energy and Temperature Coefficient	3-22
3-13	Activation Pulse Width	3-25
3-14	Temperature Characteristics of the Thermistor	3-28
3-15	General Specifications of the Step Motor	3-31
3-16	Excitation Sequence	3-34
3-17	Out-of-paper Sensor	3-36
3-18	General Specifications of the Platen Position Sensor	3-37
3-19	Cutter Home Position Sensor.....	3-39
4-1	Recommended Connectors	4-1
4-2	Terminal Assignments of the Printer Connecting Terminal (CAPD245).....	4-2
4-3	Terminal Assignments of the Autocutter Connecting Terminal	4-4
6-1	Allowable Dimensions	6-5
6-2	The Rotation Center Area for the Platen Block Rotation System of the Door	6-6

CHAPTER 1

PRECAUTIONS

Read through this technical reference to design a product and to operate the printer properly. Pay special attention to the precautions noted in each section for details. Information contained in this technical reference is subject to change without notice. For the latest information, contact our sales representative.

Sufficient evaluation and confirmation should be performed with the designed outer case mounted, to ensure proper use of the printer.

SII shall not be liable for any damages and/or loss that are caused by improper handling of the printer, any use not contained in this technical reference or that result from the outer case, unless such damages and/or loss originate from the printer itself.

SII has not investigated the intellectual property rights of the sample circuits included in this technical reference. Fully investigate the intellectual property rights of these circuits before using.

The printer is designed and manufactured to be mounted onto general electronic equipment. If high reliability is required of the printer in respect to hazardous influences on the body or life and loss to property, redundant design of the entire system should be carried out and verify the performance with your actual device before commercialization. And our sales representative should be informed as such in advance.

Follow the precautions listed below when designing a product using the printer. Include any necessary precautions into your operation manual to ensure safe operation of your product by users.

1.1 SAFETY PRECAUTIONS

Follow the precautions listed below when designing a product using the printer. Include any necessary precautions into your operation manual and attach warning labels to your products to ensure safe operation.

- **Precautions for cutting the thermal paper**

Make sure the thermal paper feed has been in a stop state when cutting the thermal paper. Paper powders can be caused while the autocutter is working. Be sure to design an outer case not to have the paper powders piled up on the control board and the power supply as this may cause short circuit failure.

- **Precautions for cutter blade**

In this printer, the platen block is removable from a printer main body so that the thermal paper can be set easily. Therefore, when the platen block is in open state, the fixed cutter blade becomes exposed. To prevent the users from injuring himself/herself by touching the cutter blades while the autocutter is in operation and replacing the thermal paper, design a structure such as a shutter in the outer case or place warning labels to warn users to ensure safe operation. Also, warn users not to touch the cutter blades directly during unpacking or assembling the printer into the outer case.

- **Precautions for the movable blade drive**

Control the motor not to drive when the platen block is in open state. Also, be sure to design the paper exit to prevent the users from injuring himself/herself by touching the autocutter directly while the autocutter is operating.

- **Precautions to prevent the thermal head from overheating**

When the thermal head heat elements are continuously activated by a CPU or other malfunction, the thermal head may overheat and may cause smoke and fire. Follow the method described in Chapter 3 "Detecting abnormal temperatures by hardware" to monitor the temperature of the thermal head to prevent overheating. Turn the printer off immediately if any abnormal conditions occur.

- **Precautions for rising temperatures of the thermal head**

Temperature of the thermal head and its peripherals rises very high during and immediately after printing. Be sure to design the outer case to prevent users from burn injuries by touching them. Place warning labels to warn users to ensure safe operation. As for thermal head cleaning, warn users to allow the thermal head to cool before cleaning. In order to allow cooling, secure clearance between the thermal head and the outer case when designing the outer case.

- **Precautions for rising temperatures of the motor**

Temperature of the motor and its peripherals rises very high during and immediately after printing. Be sure to design the outer case to prevent users from burn injuries by touching them. Place warning labels to warn users to ensure safe operation. In order to allow cooling, secure clearance between the motor and the outer case when designing the outer case.

- **Precautions for sharp edges of the printer**

The printer may have some sharp edges and cutting surface of the metal parts. Be sure to design the outer case to prevent the users from injuring himself/herself by touching the sharp edges and place warning labels to warn users to ensure safe operation.

- **Precautions for motor drive**

The hair may get caught in the exposed platen and the gears. Control the printer drive motor not to drive when the outer case and the platen block are in open state. Also, make sure to design the outer case so as not to touch the platen and the gears and also prevent any objects from getting caught. Place warning labels to warn users to ensure safe operation.

1.2 DESIGN AND HANDLING PRECAUTIONS

To maintain the primary performance of the printer and to prevent future problems from occurring, follow the precautions below.

1.2.1 Design Precautions

- Apply power in the following manner:
At power on : 1) V_{dd} → 2) V_P
At shut down : 1) V_P → 2) V_{dd}
- A surge voltage between V_P and GND should not exceed 10V.
- For noise countermeasure, connect a 0.1 μ F capacitor between V_{dd} and GND pins near the connector.
- Make the wire resistance between the power supply (V_P and GND) and the printer (connecting terminals) as small as possible (below 50m Ω). Keep distance from signal lines to reduce electrical interference.
- Keep the V_P power off while not printing in order to prevent the thermal head from electrolytic corrosion. In addition, design the product so that the Signal Ground (SG) of the thermal head and the Frame Ground (FG) of the printer become the same electric potential.
- Use C-MOS IC chips for CLK, \overline{LAT} , DI and DST signals of the thermal head.
- When turning the power on or off, or during not printing, always disable the DST terminals.
- To prevent the thermal head from being damaged by static electricity:
Connect on the printer main body and the platen block to the Frame Ground (FG) of the outer case. See Chapter 6 "OUTER CASE DESIGN GUIDE" for details.
Verify the performance with your actual device.
- Always detect the outputs of the platen position sensor and out-of-paper sensor. Never activate the thermal head when the platen block is in open state and when there is no paper. Incorrect activation of the thermal head may reduce the life of the thermal head and the platen or may damage them.
- Always detect the outputs of the platen position sensor and out-of-paper sensor. Never activate the cutter drive motor when the platen block is in open state and when there is no thermal paper. Cannot set the platen block. And incorrect activation of the cutter drive motor may reduce the life of the autocutter.
- A pause time between thermal head activations of the same heat element shall be secured more than 0.5ms. Pay attention to when using one division printing or when a thermal head activation time becomes longer. If activating for a long time without the pause time, the thermal head may become damaged.
- If too much energy is applied to the thermal head, it may overheat and become damaged. Always use the printer with the specified amount of energy shown in Chapter 3 "CONTROLLING THE ACTIVATION PULSE WIDTH FOR THERMAL HEAD".
- Noise and vibration during printing vary depending on the motor pulse rate. Verify the performance with your actual device.
- Paper feed force can be decreased depending on the motor pulse rate. Verify the performance with your actual device.
- Refer to Chapter 3 "Printer Drive Motor Drive Method" and "Autocutter Drive Motor Drive Method" to prevent the motor from overheating. And make sure the temperature of the motor outer case is 100°C or less. Verify the performance with your actual device.

- Paper feeding may be confused with several dot lines when printing is started from waiting status. When printing and paper feeding are interrupted and then started printing, as this may cause the paper feeding be confused. It especially affects printing of bit images. Always feed the thermal paper for more than 48 steps at start up or do not interrupt printing.
- To prevent degradation in the print quality due to the backlash of the paper drive system, feed the thermal paper for 48 steps or more at the initialization, at a time after setting/releasing the platen block, and a time after cutting with the autocutter.
- The printer has been left for long period of time after cutting the thermal paper, may occur the paper jam. To prevent this case, printing or feeding 2mm or more after cutting.
- Do not feed the thermal paper backwards no more than 9mm. However, the thermal paper is fed backwards no more than 7mm after cutting end. If the thermal paper is out of the holding status with the thermal head and the platen, the printer cannot feed. The surface of thermal paper may get scratched by backward feed. The backward feed may cause paper skew and jams depending on the paper roll layout and designing of the paper holder. Verify the performance with your actual device.
- Do not feed paper backwards after cutting with the partial cut. The part of the partial cut (tab left at the center) may be cut off.
- If printing at a high print ratio for longer length, non-printing area may be colored due to an accumulation of heat. Verify the performance with your actual device.
- The rotation system of the door on the outer case that holds the platen block must be set by pushing the center of the platen block. If only one end of the platen block is set, a print defect, a paper jam, the cut failure and/or the cutter blade damage may occur. Verify the performance with your actual device. In order to be pushed the center of the platen block to set it, put an indication to do so.
- If the printer main body with the movable blade and the platen block with the fixed blade are not placed in proper position, the print defect, the paper jam, and/or the cut failure may occur. Therefore, pay special attention to it when designing the outer case. For the position relation between the printer main body and the platen block, see Chapter 6 “OUTER CASE DESIGN GUIDE”.
- Design the outer case to ensure enough space to allow the users to handle the platen release lever easily with fingers.
- If designing the outer case with a structure to bring the platen block up automatically using a spring property after released, make sure not to apply more than enough force to bring the platen block up. If designing a structure that the only one side of the outer case is brought up, the position relation between the printer main body with the movable blade and the platen block with the fixed blade will be improperly and will result in the print defect or the cut failure. Verify the performance with your actual device.
- Design the thermal paper supply system in accordance with Chapter 6 “OUTER CASE DESIGN GUIDE”. When the thermal paper supply position is improper, the surface of thermal paper may get scratched, the print defect or the thermal paper detection difficulty will be caused. Verify the performance with your actual device.
- Do not use the paper except specified thermal paper. Do not use labeling paper, 2-ply thermal paper, and perforated thermal paper.
- Design the product so that a tension force is not applied to the FPC. The FPC could be moved by setting/releasing the platen block, so design the product so that the FPC has enough play after connected it. The tension force may cause some print problems and may damage the FPC.
- Metal parts may become discolored and rusted due to the operational environment. Consider these factors regarding appearance.

1.2.2 Handling Precautions

Incorrect handling may reduce the efficiency of the printer and cause damage. Handle the printer with the following precautions.

Also, include any necessary precautions so that users handle the printer with care.

- Using anything other than the specified thermal paper does not guarantee print quality and life of the thermal head.
The followings are examples of trouble:
 - (1) Poor printing quality due to low thermal sensitivity
 - (2) Abrasion of the thermal head due to the thermal paper surface roughness
 - (3) Printing stuck and unusual noise due to sticking the thermal layer of the thermal paper to the thermal head
 - (4) Printing fade due to low preservability of the thermal paper
 - (5) Electrolytic corrosion of the thermal head due to inferior paper
 - (6) Cutter malfunction due to variety of the thermal paper thickness (and mechanical strength and paper density).
- After the printer has been left not in use for long period of time, the platen could be deformed and resulted in print quality deteriorated. In this case, feed thermal paper for a while to recover deformation of the platen. If the thermal head is remained in contact with the platen without thermal paper for a long time, the platen and the thermal head may be stuck together and cause paper feed difficulty. If facing this problem, release the platen block and set it back again before starting printing.
- Never loosen the screws that fasten respective parts of the printer. Loosened screws may reduce the efficiency of the printer mechanism and the autocutter.
- Do not wipe oil that coating on the autocutter (movable blade and the fixed blade). It may reduce the efficiency of the autocutter.
- Do not release the platen block during printing and cutting; otherwise this may reduce the efficiency of the printer.
- When setting the platen block, the reduction gear may interfere with the platen gear and may cause the platen block to not be set. In such a case, release the platen block and set it again.
- Never pull out the thermal paper while the platen block is set. The printer may become damaged.
- Do not apply stress to the platen block while printing and cutting. The print defect and the cut failure may occur.
- When handling the printer, make sure to use antistatic clothing and to ground yourself to prevent the thermal head from damaged by static electricity. Especially take care of the thermal head heat element and the connecting terminal.
- Do not hit or scratch the surface of the thermal head with any sharp or hard object. This could damage the thermal head.
- When printing at a high print ratio in a low temperature or high humidity environment, the vapor from the thermal paper during printing may cause condensation to form on the printer mechanism and soil the thermal paper itself. Prevent the thermal head from a drop of water. It may cause electrolytic corrosion of the thermal head. If condensed, do not activate electricity until dried.
- Connect or disconnect the connecting terminal (the printer connecting terminal and the autocutter connecting terminal) after turn off the power of the printer.
- Do not apply stress to the FPC while connecting and disconnecting the connecting terminal (the printer connecting terminal and the autocutter connecting terminal). Otherwise the FPC may become damaged.

- Warn users not to pull the thermal paper and to change an angle of the thermal paper discharge during printing and cutting. Otherwise, the print defect, the paper jam, and/or the cut failure may occur.
- Warn users to remove the thermal paper which cut with the full cut, then perform the next printing or cutting.
If the thermal paper does not remove and perform the next printing or cutting, it may cause of the paper jam or cut failure depending on the mounting position.
- In order to prevent the thermal head from damage and to avoid the print defect, warn the users not to touch the thermal head and the sensor directly when handling the printer like replacing thermal paper.
- Do not use the paper roll with glued end or folded end. In case of using such papers, replace to a new one before the end of the paper roll is shown up.
- The printer is not waterproof and drip proof. Prevent contact with water and do not operate with wet hands as it may damage the printer or may cause a short circuit or fire.
- The printer is not dust proof. If use the printer in a dusty place, it may damage the thermal head, paper drive system or reduce the efficiency of the autocutter.
- Do not use the printer in corrosive gas and siloxane atmosphere as it may cause the contact failure.

1.2.3 Precautions on Discarding

When discarding used printer, discard them according to the disposal regulations and rules of each respective district.

CHAPTER 2

FEATURES

The printer which has the thermal line dot printing method integrated the autocutter with the slide cutting method. It can be used with measuring instruments and analyzer, a POS, a communication terminal device, or a data terminal device.

The printer has the following features:

- **High resolution Printing**
A high-density print head of 8 dots/mm produces clear and precise printing.
- **Compact and light weight**
The printer realizes reduction in size and weight by the printer integrated the autocutter.
- **High print speed***
Maximum 100mm/s print is available.
- **High reliability autocutter**
The original platen block positioning structure can assure the certain cutting performance constantly.
- **Easy operation**
Platen block open mechanism provides easy paper installation.
- **Auto-loading**
The printer to load the thermal paper automatically with the auto-loading function.
- **Maintenance Free**
No cleaning and no maintenance required.
- **Low noise**
Thermal printing technology realizes low-noise print.

*: Print speed is different according to use conditions.

CHAPTER 3 SPECIFICATIONS

3.1 GENERAL SPECIFICATIONS

Table 3-1 lists the general specifications of the printer.

Table 3-1 General Specifications

(1/3)

Items	Specifications
Printing method	Thermal dot line printing
Total dots per line	384 dots
Printable dots per line	384 dots
Simultaneously activated dots	96 dots
Resolution	W 8 dots/mm × H 16 dots/mm
Paper feed pitch	0.03125mm
Maximum print speed	100mm/s ^{*1}
Print width	48mm
Paper width	58 ⁰ ₋₁ mm
Thermal head temperature detection	Thermistor
Platen position detection	Mechanical switch
Out-of-paper detection	Reflection type photo interrupter
Cutter home position detection	Transmissive type photo interrupter
Operating voltage range V _P line V _{dd} line	4.75 to 9.5V 2.7 to 3.6V, 4.75 to 5.25V
Current consumption V _P line Thermal head drive Motor drive V _{dd} line Thermal head Logic	5.49A max. (at 9.5V) ^{*2} 0.60A max. 0.10A max.
Autocutter current consumption V _P line Motor driving	0.60A max.

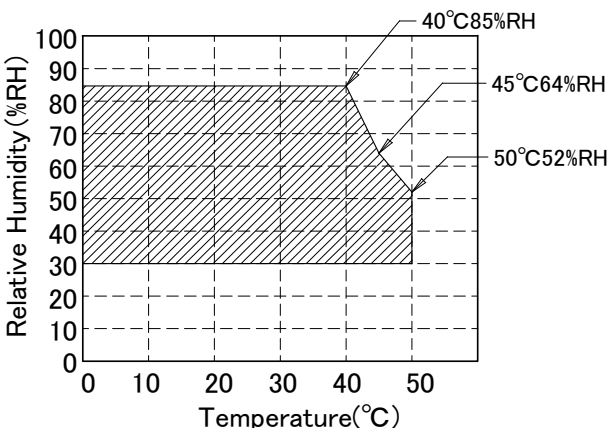
Items		Specifications
Paper cutting method		Slide cutting
Type of paper cutting		Full cut and Partial cut (1.5±0.5mm tab left at the center)
Paper curling tendency		Fixed blade side and Movable blade side
Minimum paper core diameter		φ 8 (paper thickness : 75μm below) φ 18(paper thickness : 75μm more)
Minimum paper cutting length		10mm
Operating time		approx. 1.0s/cycle
Cutting frequency		max. 30 cuts / minutes ^{*3}
Operating temperature and humidity range		-10 to 50°C (Non condensing) 
Storage temperature range		-20 to 60°C (Non condensing)
Life span (at 25°C and rated energy)	Activation pulse resistance	100 million pulses or more ^{*4}
	Abrasion resistance	50km or more (excluding damage caused by dust and foreign materials)
	Paper cutting resistance	500,000 cuts or more ^{*5}
Paper feed force		0.49N (50gf) or more
Paper hold force		0.78N (80gf) or more
Dimensions ^{*6} including mounting part		W83.1mm × D35.4mm × H26.9mm W83.1mm × D43.9mm × H27.4mm
Mass		approx. 125g

Items	Specifications	
Specified thermal paper ^{*7}	Nippon Paper	TF50KS-E2D TP50KJ-R
	Oji Paper	PD160R-63 PD160R-N
	Mitsubishi Paper mills limited	P220VBB-1
	Jujo Thermal	AP50KS-D AF50KS-E
	Mitsubishi Hi-Tech Paper	F5041
	Papierfabrik August Koehler AG	KT55F20
	KSP	P350
	KANZAN	KF50

*1 : Print speed changes according to the processing speed of the controller and print pulse width.

*2 : The value when the number of simultaneously activated dots is 96 dots.

*3 : 2.0 s/cycle

*4 : Excluded when the same dots are printed continuously.

*5 : Paper cutting environment : Room temperature and humidity, the shape of the paper exit described in Chapter 6.

*6 : Excluded convex part.

*7 : Do not use perforated thermal paper.

3.2 PRINT CONFIGURATION

Figure 3-1 shows dot pitch. Figure 3-2 shows print area.

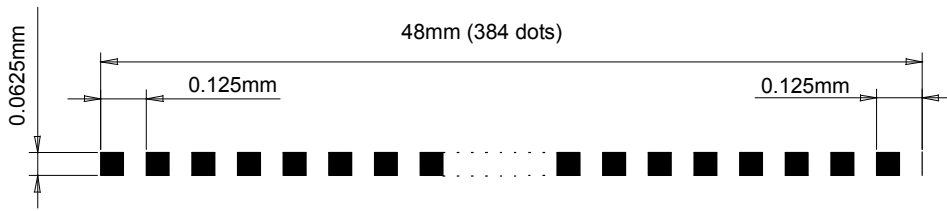

Figure 3-1 Dot Pitch

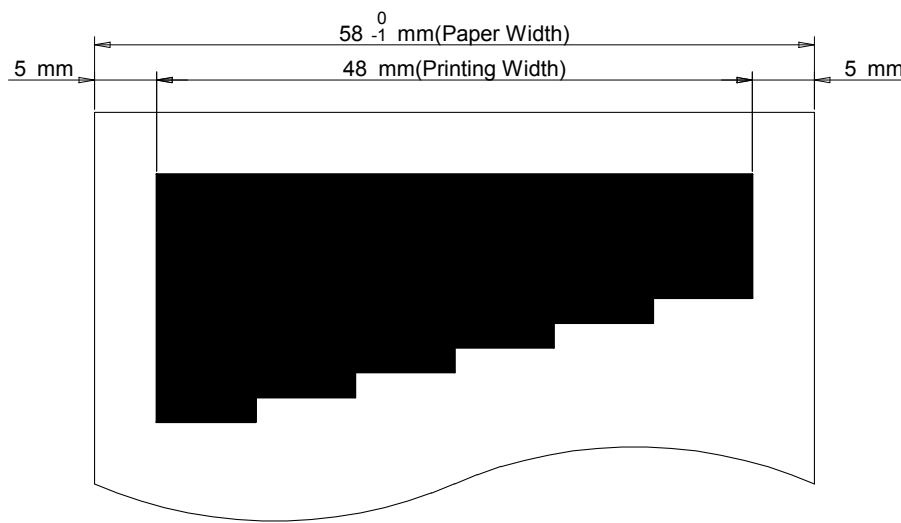

Figure 3-2 Print Area

3.3 STEP MOTOR (PRINTER DRIVE MOTOR)

3.3.1 General Specifications

Table 3-2 shows general specifications of the step motor.

Table 3-2 General Specifications of the Step Motor

Item	Specifications
Type	PM type step motor
Drive method	Bi-polar chopper
Excitation	1-2 phase
Winding resistance per phase	12Ω/phase ±10%
Motor drive voltage	V _P : 4.75 to 9.5V
Motor controlled current	300 mA/phase
Drive pulse rate	3200pps max.

3.3.2 Sample Drive Circuit

Figure 3-3a shows the sample drive circuit 1, when the current is controlled with VREF of the motor driver output.

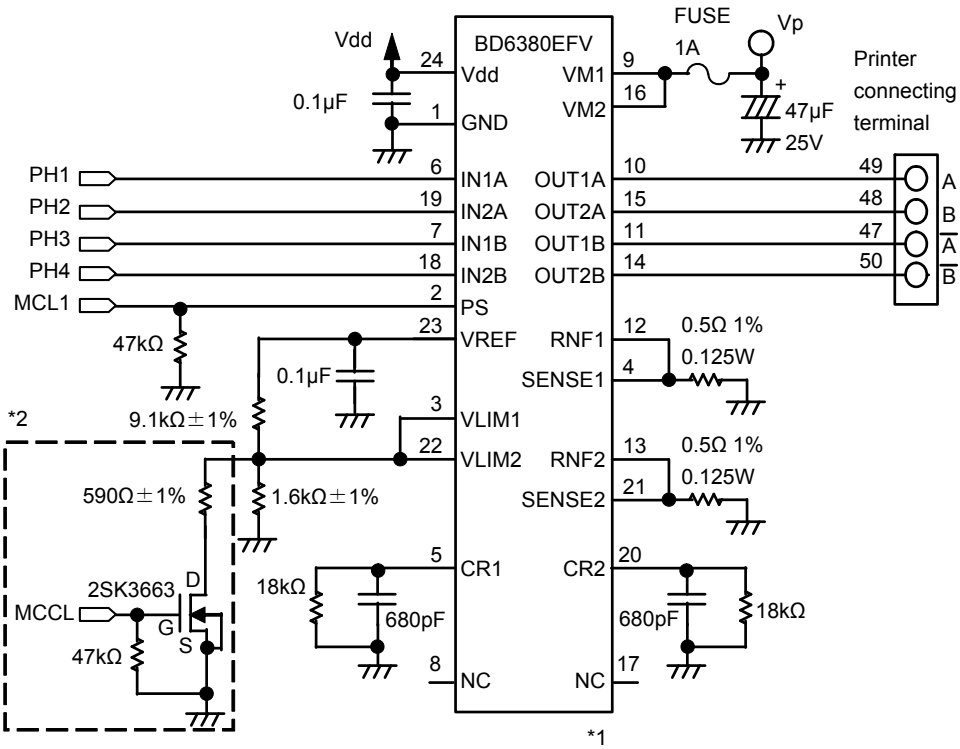

*1: Recommended motor driver : BD6380EFV (ROHM)

*2: The circuit inside the dashed frame, that is necessary for exciting the printer drive motor after the partial cut. The motor is excited by 90mA during MCCL is "High".

Figure 3-3a Sample Drive Circuit 1

Figure 3-3b shows the sample drive circuit 2, when the current is controlled without VREF of the motor driver output. (using the D/A converter etc.)

- **MREF signal**

It is the reference signal for the motor current control. The motor drive setting current is set by the MREF signal setting voltage.

CAPD245	Paper feeding / Print (300mA):	150mV ± 5%
	Excite after the partial cut (90mA):	45mV ± 5%

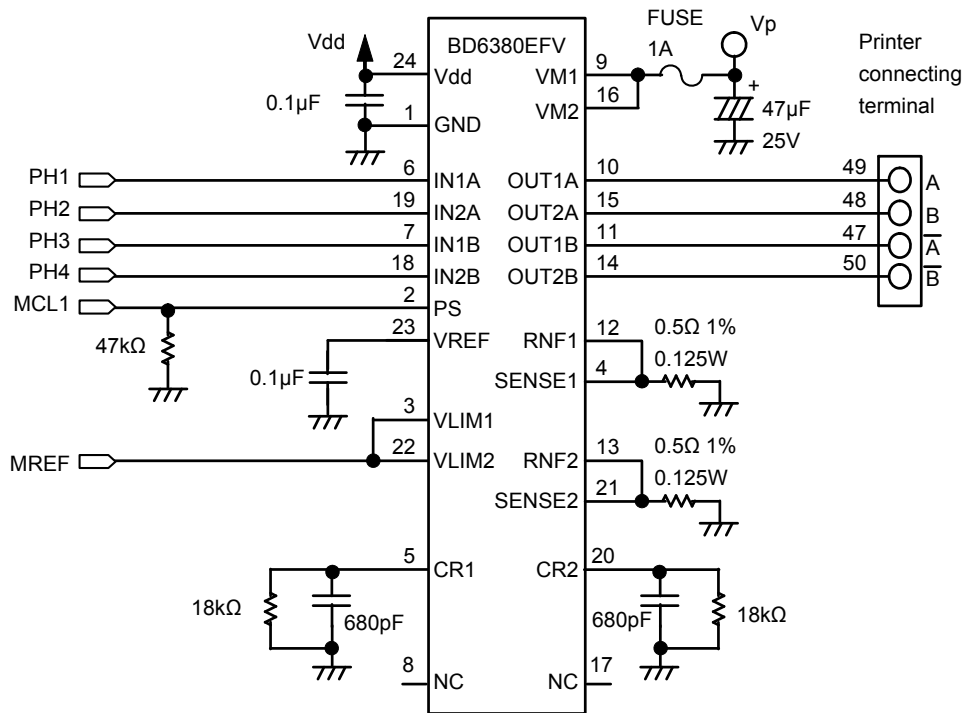

*: Recommended motor driver : BD6380EFV (ROHM)

Figure 3-3b Sample Drive Circuit 2

3.3.3 Excitation Sequence

Drive the motor with 1-2 phase excitation. One step of the motor drive signal feeds the thermal paper 0.03125 mm. One dot line is consisted of 4 steps. When the voltage signal shown in Figure 3-4 is input to the motor drive circuit shown in Figure 3-3, the printer feeds the thermal paper to the forward direction when the motor is excited in order of step 1, step 2, step 3, step 4, step 5, step 6, step 7, step 8, step 1, step 2, , as shown in Table 3-3.

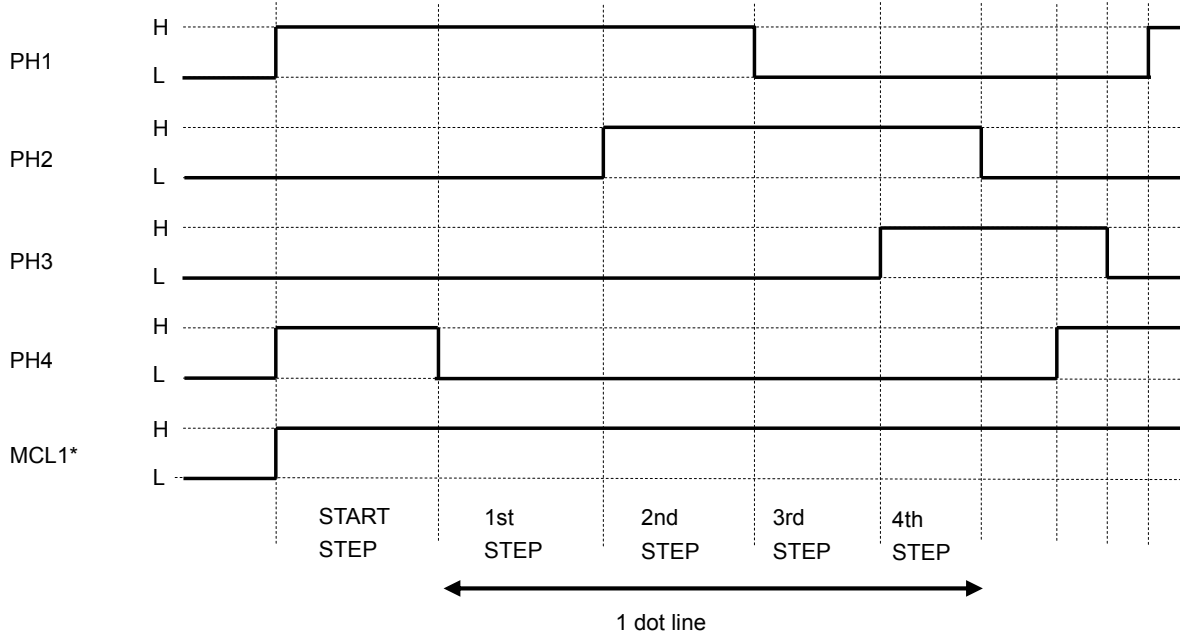

*: Set MCL1 to "High" while the motor is driven.

Figure 3-4 Input Voltage Waveforms for the Sample Drive Circuit

Table 3-3 Excitation Sequence

	Input Signal				Output Signal			
	PH1	PH2	PH3	PH4	A	B	\bar{A}	\bar{B}
Step 1	H	L	L	L	H	OPEN	L	OPEN
Step 2	H	H	L	L	H	H	L	L
Step 3	L	H	L	L	OPEN	H	OPEN	L
Step 4	L	H	H	L	L	H	H	L
Step 5	L	L	H	L	L	OPEN	H	OPEN
Step 6	L	L	H	H	L	L	H	H
Step 7	L	L	L	H	OPEN	L	OPEN	H
Step 8	H	L	L	H	H	L	L	H

3.3.4 Printer Drive Motor Start/Stop Method

Refer to the timing chart in Figure 3-5 when designing the control circuit or software for starting and stopping the motor. Also note the following precautions:

(1) Start step

To start the motor from the pause (no excitation) state, shift the motor to the sequence of print step after exciting the same phase as that of the stop step for the first start step time.

To restart the motor from the stop step, immediately shift the motor to the sequence of print step.

(2) Stop step

To stop the motor, excite the same phase as the last one in the print step for 20ms.

(3) Pause state

In the pause state, do not excite the motor to prevent to the motor from overheating. Even when the motor is not excited, holding torque of the motor prevents the thermal paper from moving.

When the user takes the thermal paper after the partial cut, the thermal paper may be pulled out of the printer by its direction to be pulled.

It is recommended to excite the printer drive motor at the pause state after the partial cut, to prevent the thermal paper is pulled.

If the printer drive motor is excited at the pause state, input the signal of the previous stop step to PH1 to PH4 and MCL1, excite the printer drive motor with Figure 3-3a and Figure 3-3b.

The printer drive motor produces heat by its excitation, and so setting the excitation time with sufficient estimation.

Input signals for a sample drive circuit are shown in Figure 3-5.

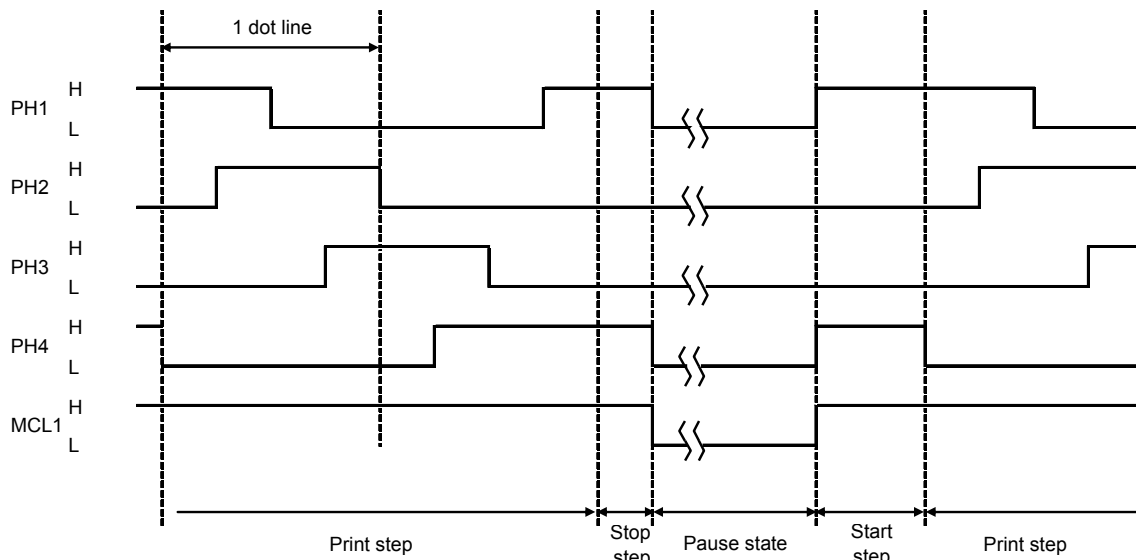

Figure 3-5 Printer Drive Motor Start/Stop Timing Chart

3.3.5 Printer Drive Motor Drive Method

Drive the printer drive motor by the following methods.

(1) Motor drive pulse rate

During paper feeding, the motor should be driven equal or lower the value of Equation (1).

Equation (1):

$$\text{CAPD245 : } P_M = V_P \times 534 - 1339 \text{ (pps)}$$

- P_M : Maximum motor drive pulse rate at V_P (pps)
However, 3200pps max.
- V_P : Motor drive voltage (V)

Table 3-4 Maximum Motor Drive Pulse Rate

V_P	Drive Pulse Rate
4.75V	1198 pps
5.5V	1598 pps
6.0V	1865 pps
7.2V	2506 pps
8.0V	2933 pps
8.5V	3200 pps
9.5V	3200 pps

The motor drive pulse rate while auto-loading, it is different according to the length of the auto-loading performed.

The length of the auto-loading performed 300mm or shorter, the motor is driven by the motor drive pulse rate at 320pps regardless of the motor drive voltage.

The length of the auto-loading performed longer than 300mm, the motor is driven by the motor drive pulse rate at 320pps until the auto-loading length is 300mm.

If the length of the auto-loading performed longer than 300mm, the motor is driven by the maximum motor drive pulse rate P_M that calculated by the motor drive voltage.

(2) Speed control

When driving the printer drive motor, the acceleration control is required to maintain the paper feed force of start up (include during auto-loading). If acceleration of the motor does not perform correctly, the motor may step out if it has a heavy workload. Accelerate the speed sequentially up to the maximum motor drive pulse rate P_M according to Table 3-5 Acceleration Steps (CAPD245).

Acceleration should be performed by the acceleration step time below, that is output the phase.

1. Drive the start step as same as acceleration step time at Start acceleration step.
2. Drive the first step as same as acceleration step time at 1st acceleration step.
3. Drive the second step as same as acceleration step time at 2nd acceleration step.
4. Hereinafter, drive the "n"th step as same as acceleration step time at "n"th acceleration step.
5. After accelerating up to the maximum motor drive pulse rate P_M , drive the motor at a constant speed.

Available to print during acceleration.

The activation time of the thermal head may be longer than the motor step time depending on the type of the thermal paper, content of the printing and use conditions. In this case, drive the printer drive motor so that the motor driving composition of 1st and 2nd step of the half dot line divides the thermal head activation time equally.

Follow the procedures below if :

Unable to accelerate the speed for the reasons above even if following Table 3-5.

The speed has been reduced at a certain speed and then accelerates the speed again.

The next step time after reducing the speed is the nearest acceleration step time, which should be shorter than the previous acceleration step time and longest.

(ex) According to Table 3-5, if the motor acceleration step time of the previous step is $900\mu\text{s}$, the next step should be the 10th acceleration step ($880\mu\text{s}$).

Hereinafter, accelerate the speed sequentially up to the maximum motor drive pulse rate P_M according to Table 3-5.

Table 3-5 Acceleration Steps (CAPD245)

Number of Steps	Speed (pps)	Step Time (μs)	Number of Steps	Speed (pps)	Step Time (μs)
Start	-	5000	37	2274	440
1	270	3707	38	2305	434
2	436	2291	39	2337	428
3	565	1769	40	2367	422
4	673	1485	41	2398	417
5	768	1302	42	2428	412
6	853	1172	43	2457	407
7	931	1074	44	2487	402
8	1004	996	45	2515	398
9	1072	933	46	2544	393
10	1136	880	47	2572	389
11	1197	836	48	2600	385
12	1255	797	49	2628	381
13	1310	763	50	2655	377
14	1364	733	51	2683	373
15	1415	707	52	2709	369
16	1465	683	53	2736	365
17	1513	661	54	2762	362
18	1560	641	55	2788	359
19	1605	623	56	2814	355
20	1649	606	57	2840	352
21	1692	591	58	2865	349
22	1734	577	59	2891	346
23	1775	563	60	2916	343
24	1815	551	61	2940	340
25	1854	539	62	2965	337
26	1893	528	63	2989	335
27	1930	518	64	3013	332
28	1967	508	65	3037	329
29	2004	499	66	3061	327
30	2039	490	67	3085	324
31	2075	482	68	3108	322
32	2109	474	69	3131	319
33	2143	467	70	3154	317
34	2176	459	71	3177	315
35	2209	453	72	3200	313
36	2242	446	-	-	-

(3) Preventing overheat

To prevent the motor from overheating, the drive time and drive ratio are limited.

Follow the Table 3-6 and Table 3-7, or Table 3-8 shown below to set an operating time and a pause time of the motor.

Temperature rise of the motor is different according to the use conditions. (ambient temperature, designing the outer case etc.) Keep the temperature of the motor outer case, 100°C or lower. Verify the performance with your actual device.

Table 3-6 Maximum Continuous Drive Time / Length (1): Temperature Rise 50°C

Drive pulse rate (pps)	Motor drive voltage V_p (V)									
	$9.5 \geq V_p > 8.5V$		$8.5 \geq V_p > 7.5V$		$7.5 \geq V_p > 6.5V$		$6.5 \geq V_p > 5.5V$		$5.5 \geq V_p \geq 4.75V$	
	(min)	(m)	(min)	(m)	(min)	(m)	(min)	(m)	(min)	(m)
320 to 560	5.1	3.1 or longer	5.2	3.1 or longer	5.1	3.1 or longer	4.9	3.0 or longer	5.2	3.1 or longer
560 to 800	4.9	5.2 or longer	5.2	5.4 or longer	5.1	5.3 or longer	5.3	5.5 or longer	5.8	6.1 or longer
800 to 1040	4.9	7.4 or longer	5.2	7.8 or longer	5.3	7.9 or longer	5.6	8.4 or longer	6.4	9.6 or longer
1040 to 1280	4.8	9.4 or longer	5.0	9.8 or longer	5.2	10.1 or longer	5.8	11.4 or longer	7.1	13.8 or longer
1280 to 1520	4.8	11.6 or longer	5.1	12.2 or longer	5.5	13.2 or longer	6.6	15.8 or longer	9.0	21.6 or longer
1520 to 1760	4.8	13.8 or longer	5.3	15.0 or longer	6.0	17.1 or longer	7.1	20.2 or longer	12.4	35.4 or longer
1760 to 2000	4.8	16.0 or longer	5.3	17.6 or longer	6.2	20.4 or longer	8.3	27.5 or longer	×	×
2000 to 2240	5.0	18.8 or longer	5.3	20.0 or longer	6.7	25.0 or longer	10.0	37.5 or longer	×	×
2240 to 2480	4.9	20.7 or longer	5.4	22.8 or longer	7.4	31.2 or longer	×	×	×	×
2480 to 2720	5.1	23.6 or longer	5.9	27.5 or longer	8.4	39.1 or longer	×	×	×	×
2720 to 2960	5.2	26.4 or longer	6.7	34.0 or longer	×	×	×	×	×	×
2960 to 3200	5.6	31.0 or longer	7.4	41.2 or longer	×	×	×	×	×	×
3200	5.6	33.5 or longer	8.3	49.5 or longer	×	×	×	×	×	×

× : Unusable

Table 3-7 Drive Rate: Temperature Rise 50°C

Drive pulse rate (pps)	Motor drive voltage V_p (V)				
	$9.5 \geq V_p > 8.5V$	$8.5 \geq V_p > 7.5V$	$7.5 \geq V_p > 6.5V$	$6.5 \geq V_p > 5.5V$	$5.5 \geq V_p \geq 4.75V$
320 to 560	41.7%	41.7%	42.6%	43.2%	43.9%
560 to 800	45.7%	45.7%	45.7%	47.6%	54.9%
800 to 1040	48.8%	48.8%	48.8%	51.3%	57.1%
1040 to 1280	49.6%	49.6%	50.9%	54.0%	59.2%
1280 to 1520	50.0%	50.0%	52.1%	56.8%	67.6%
1520 to 1760	50.1%	50.1%	54.0%	61.9%	75.2%
1760 to 2000	49.1%	51.9%	58.7%	64.9%	×
2000 to 2240	51.6%	53.3%	59.3%	72.7%	×
2240 to 2480	51.0%	57.1%	64.9%	×	×
2480 to 2720	51.6%	58.7%	67.9%	×	×
2720 to 2960	53.5%	60.3%	×	×	×
2960 to 3200	56.9%	61.8%	×	×	×
3200	58.8%	66.7%	×	×	×

× : Unusable

$$\text{Drive Ratio(\%)} = \frac{\text{Drive Time}}{\text{Drive Time} + \text{Pause Time}} \times 100(\%)$$

Table 3-8 Maximum Continuous Drive Time / Length (2): Temperature Rise 75°C (Reference)

Drive pulse rate (pps)	Motor drive voltage V_p (V)									
	$9.5 \geq V_p > 8.5V$		$8.5 \geq V_p > 7.5V$		$7.5 \geq V_p > 6.5V$		$6.5 \geq V_p > 5.5V$		$5.5 \geq V_p \geq 4.75V$	
	(min)	(m)	(min)	(m)	(min)	(m)	(min)	(m)	(min)	(m)
320 to 560	11.7	7.0 or longer	11.9	7.2 or longer	11.8	7.1 or longer	11.1	6.7 or longer	12.9	7.8 or longer
560 to 800	11.3	11.8 or longer	12.1	12.7 or longer	12.1	12.7 or longer	12.7	13.3 or longer	18.3	19.2 or longer
800 to 1040	11.4	17.1 or longer	12.4	18.6 or longer	12.9	19.4 or longer	15.5	23.3 or longer	27.3	41.0 or longer
1040 to 1280	11.2	21.8 or longer	12.1	23.6 or longer	13.1	25.5 or longer	16.8	32.8 or longer	60.0 or longer	117.0 or longer
1280 to 1520	11.4	27.4 or longer	12.8	30.8 or longer	14.9	35.8 or longer	24.5	58.8 or longer	60.0 or longer	144.0 or longer
1520 to 1760	11.7	33.3 or longer	13.4	38.2 or longer	18.1	51.5 or longer	60.0 or longer	171.0 or longer	60.0 or longer	171.0 or longer
1760 to 2000	11.9	39.3 or longer	14.3	47.0 or longer	22.0	72.6 or longer	60.0 or longer	198.0 or longer	×	×
2000 to 2240	12.4	46.6 or longer	14.8	55.6 or longer	36.7	137.5 or longer	60.0 or longer	225.0 or longer	×	×
2240 to 2480	12.7	53.2 or longer	16.4	69.0 or longer	60.0 or longer	252.0 or longer	×	×	×	×
2480 to 2720	13.8	63.9 or longer	21.3	98.8 or longer	60.0 or longer	279.0 or longer	×	×	×	×
2720 to 2960	14.9	76.1 or longer	60.0 or longer	306.0 or longer	×	×	×	×	×	×
2960 to 3200	17.8	99.0 or longer	60.0 or longer	333.0 or longer	×	×	×	×	×	×
3200	20.2	121.0 or longer	60.0 or longer	360.0 or longer	×	×	×	×	×	×

× : Unusable

3.3.6 Motor Drive Precautions

- Using the motor drive circuit other than the circuit shown in "Section 3.3.2 Sample Drive Circuit" may not ensure the specified efficiency.
- To prevent degradation in the print quality due to the backlash of the paper drive system, feed the paper for 48 steps or more at the initialization, at a time after setting/releasing the platen block, and a time after cutting with the autocutter. During this time, drive the motor with constant speed at the 1st acceleration step.
- When printing, change the motor drive pulse rate depending on the operational conditions such as voltage, temperature, and the number of activated dots. (See Chapter 5 "PRINT DRIVE METHOD" for details)
- The activation time of the thermal head can be longer than the motor step time depending on the type of the thermal paper, content of the printing and use conditions. In that case, the 1st step time and the 2nd step time of the half dot line, divide equally of the thermal head activation time. (See Chapter 5 "PRINT DRIVE METHOD" for details).
- Do not feed the thermal paper backwards no more than 9mm. However, the thermal paper is fed backwards no more than 7mm after cutting end. If the thermal paper is out of the holding status with the thermal head and the platen, the printer cannot feed.
The surface of thermal paper may get scratched by backward feed. The backward feed may cause paper skew and jams depending on the paper roll layout and designing of the paper holder. Verify the performance with your actual device.
- Do not print intermittently. (Do not repeat printing and stopping in a short interval.)
If doing so, print quality may be decreased due to unevenness of the paper feed pitch.
- Always perform the start and the stop steps for both character print and bit image print.
- For the motor stop, a minimum one dot line of motor feed is required from the step that thermal head was activated. If the motor is stopped at the step that the thermal head has been activated, paper feed difficulty may be caused due to sticking of the thermal paper to the thermal head.
- Sound and vibration during printing vary depending on the motor drive pulse rate. Verify the performance with your actual device.
- Do not drive the printer drive motor while the autocutter drive motor is driving (paper feed).
It cause of the damage of the printer.

3.4 THERMAL HEAD

The thermal head consists of heat elements and a thermal head driver that drives and controls the heat elements.

The data input from the DI terminal, print is "High" and non print is "Low". The data from the DI terminal is transferred to the shift register at the rising edge of the CLK signal.

The data is stored into the latch register by making $\overline{\text{LAT}}$ signal "Low" after one line data is transferred. The heat elements are activated by making DST signal "High" in accordance with the stored print data.

In the CAPD245, a division printing by 6 blocks, 64 dots each is available. The divided printing is effective for a high print ratio printing because the peak current can be cut down with the reduction of the average print speed.

3.4.1 Structure of the Thermal Head

Figure 3-6 shows the thermal head block diagram when driving the CAPD245.

Table 3-9 shows the relationship between DST terminals and activated heat elements.

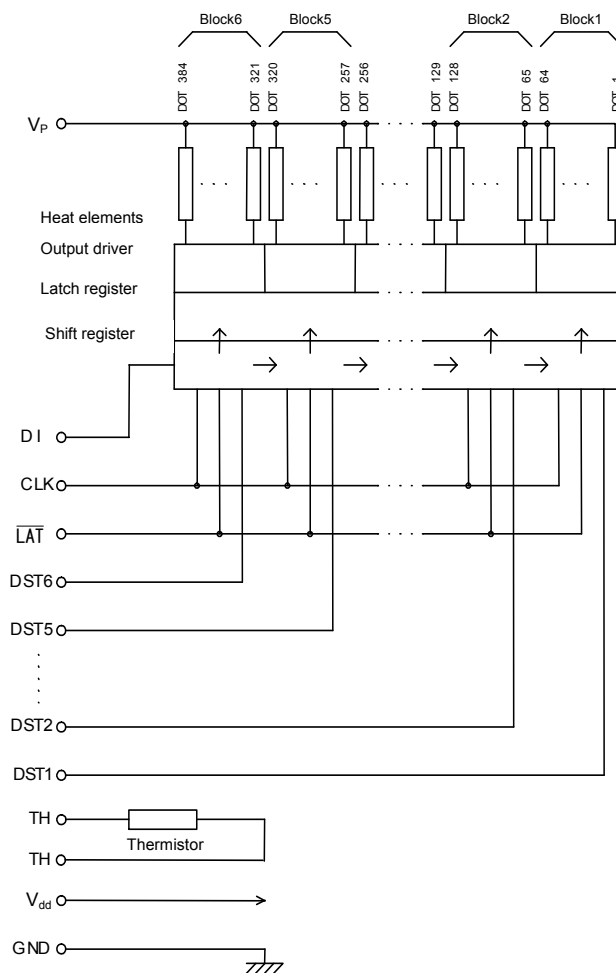

Figure 3-6 Thermal Head Block Diagram (CAPD245)

Table 3-9 DST Terminals and Activated Heating Elements (CAPD245)

Block	DST No.	Heat Element No.	Dots Number/ DST
1	DST1	1 to 64	64
2	DST2	65 to 128	64
3	DST3	129 to 192	64
4	DST4	193 to 256	64
5	DST5	257 to 320	64
6	DST6	321 to 384	64

3.4.2 Connection of Transfer Data and Print Position

Describes connection of transfer data and print position for CAPD245.

384-bit data (#1 to #384) transferred through DI terminals are printed as shown in Figure 3-7.

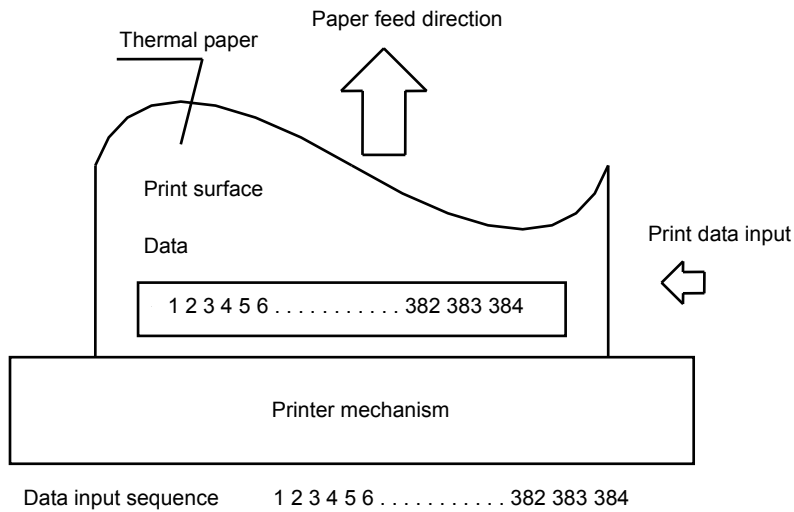

Figure 3-7 Transfer Data and Print Position (CAPD245)

3.4.3 Electrical Characteristics of Thermal Head

Table 3-10 shows electrical characteristics of thermal head.

Table 3-10 Electrical Characteristics of Thermal Head (CAPD245)

(at 25 °C)

Item	Symbol	Conditions	Rated value			Unit	
			MIN	TYP	MAX		
Thermal head heat element resistance	R_H		166.0	173.0	180.0	Ω	
Thermal head drive voltage	V_P		4.75	—	9.5	V	
Thermal head drive current	I_P	at the number of simultaneously activated dots = 96	—	—	5.49	A	
Logic voltage	V_{dd}		2.7	3.3	3.6	V	
			4.75	5	5.25	V	
Logic current	I_{dd}	$f_{DI}=1/2f_{CLK}$	—	—	36	mA	
Input voltage	High	V_{IH}	CLK, DI, \overline{LAT} , DST	$0.8V_{dd}$	—	V_{dd}	V
	Low	V_{IL}	CLK, DI, \overline{LAT} , DST	0	—	$0.2V_{dd}$	V
DI input current	High	I_{IH} DI	$V_{IH} = V_{dd}$	—	—	0.5	μA
	Low	I_{IL} DI	$V_{IL} = 0V$	—	—	-0.5	μA
DST input current	High	I_{IH} DST	$V_{dd} = 5V, V_{IH} = V_{dd}$	—	—	55	μA
	Low	I_{IL} DST	$V_{IL} = 0V$	—	—	-0.5	μA
CLK input current	High	I_{IH} CLK	$V_{IH} = V_{dd}$	—	—	1.0	μA
	Low	I_{IL} CLK	$V_{IL} = 0V$	—	—	-1.0	μA
\overline{LAT} input current	High	I_{IH} \overline{LAT}	$V_{IH} = V_{dd}$	—	—	1.0	μA
	Low	I_{IL} \overline{LAT}	$V_{IL} = 0V$	—	—	-1.0	μA
CLK frequency	f_{CLK}		$2.7V \leq V_{dd} < 3.0V$	—	—	5	MHz
			$3.0V \leq V_{dd} \leq 3.6V$	—	—	8	MHz
			$4.75V \leq V_{dd} \leq 5.25V$	—	—	8	MHz
CLK pulse width	t_1	See the timing chart.	$2.7V \leq V_{dd} < 3.0V$	50	—	—	ns
			$3.0V \leq V_{dd} \leq 3.6V$	30	—	—	ns
			$4.75V \leq V_{dd} \leq 5.25V$	30	—	—	ns
DI setup-time	t_2	See the timing chart.	$2.7V \leq V_{dd} < 3.0V$	70	—	—	ns
			$3.0V \leq V_{dd} \leq 3.6V$	30	—	—	ns
			$4.75V \leq V_{dd} \leq 5.25V$	30	—	—	ns
DI hold time	t_3	See the timing chart.	$2.7V \leq V_{dd} < 3.0V$	40	—	—	ns
			$3.0V \leq V_{dd} \leq 3.6V$	30	—	—	ns
			$4.75V \leq V_{dd} \leq 5.25V$	30	—	—	ns
\overline{LAT} setup time	t_4	See the timing chart.	100	—	—	ns	
\overline{LAT} pulse width	t_5	See the timing chart.	100	—	—	ns	
\overline{LAT} hold time	t_6	See the timing chart.	50	—	—	ns	
DST setup time	t_7	See the timing chart.	300	—	—	ns	
\overline{LAT} wait time	t_8^*	See the timing chart.	$2.7V \leq V_{dd} < 3.0V$	36	—	—	μs
			$3.0V \leq V_{dd} \leq 3.6V$	30	—	—	μs
			$4.75V \leq V_{dd} \leq 5.25V$	30	—	—	μs

*: If MIN at " \overline{LAT} wait time" in the table cannot be secured, it may cause V_P voltage fluctuations.

3.4.4 Timing Chart

Figure 3-8 shows a thermal head drive timing chart.

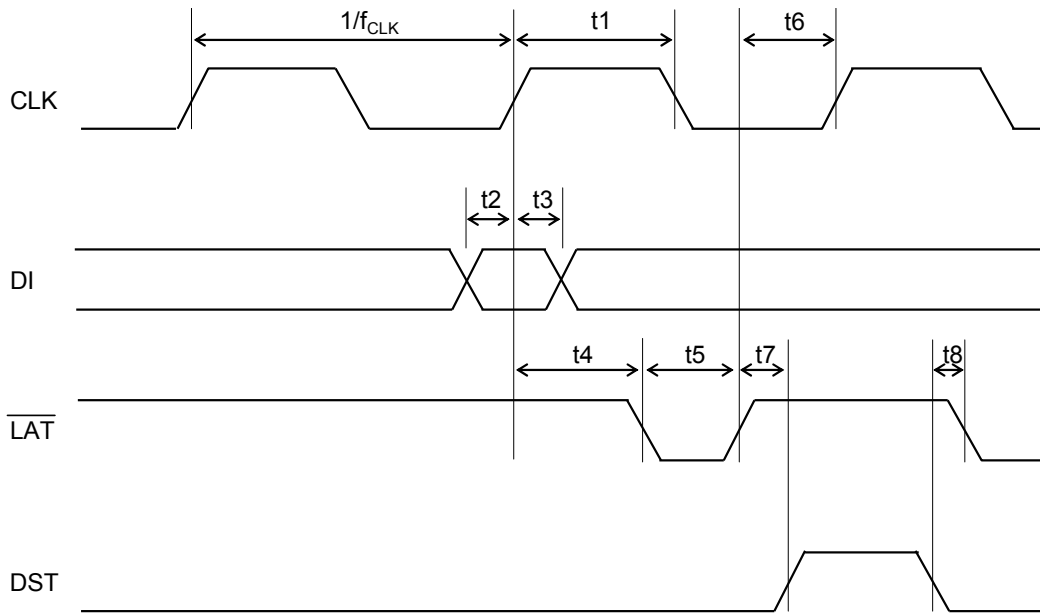

Figure 3-8 Thermal Head Drive Timing Chart

3.4.5 Thermal Head Heat Element Resistance

Table 3-11 shows resistance of the thermal head heat element of the printer.

Table 3-11 Thermal Head Heat Element Resistance

Thermal Head Heat Element Resistance
166.0 to 180.0Ω

3.4.6 Maximum Current Consumption

Since the maximum current consumption may reach the values calculated using equation (2) when the thermal head is driven, the number of simultaneously activated dots should be determined not to exceed power supply capacity. Also, allowable current for the cable material and the voltage drop on the cable should be cared well.

Equation (2):

$$I_P = \frac{N_{SA} \times V_P}{R_{H\min}}$$

- I_P : Maximum current consumption (A)
- N_{SA} : Number of simultaneously activated dots
- V_P : Thermal head drive voltage (V)
- $R_{H\min}$: Minimum thermal head heat element resistance
166.0 (Ω)

3.5 CONTROLLING THE ACTIVATION PULSE WIDTH FOR THERMAL HEAD

To execute high quality printing using the printer, the activation pulse width is controlled according to use conditions. Control printing with the activation pulse width calculated by the following sequence. Printing at too high voltage or too long activation pulse width may shorten the life of the thermal head.

3.5.1 Calculation of Activation Pulse Width

Each value can be calculated according to the steps in Section 3.5.2 to 3.5.6 and the activation pulse width “t” can be calculated by substituting each value into the equation (3).

Equation (3):

$$t = \frac{E \times R}{V^2} \times C$$

t	:	Thermal head pulse width (ms)	
E	:	Printing energy (mJ)	See section 3.5.2
R	:	Adjusted resistance (Ω)	See section 3.5.3
V	:	Adjusted voltage (V)	See section 3.5.4
C	:	Thermal head activation pulse cycle coefficient	See section 3.5.6

3.5.2 Calculation of Printing Energy

The printing energy “E” can be calculated using equation (4) as the appropriate printing energy is different depending on each specified thermal paper and the temperature of the thermal head.

Equation (4):

$$E = E_{25} - T_C \times (T_X - 25)$$

E_{25}	:	Standard printing energy	See Table 3-12
T_C	:	Temperature coefficient	See Table 3-12
T_X	:	Temperature detected by thermistor (°C) *	

* : Measure the temperature using the resistance of the built-in thermistor on the thermal head.
For the thermistor resistance value at T_X (°C), see Section 3.5.8.

Table 3-12 Standard Printing Energy and Temperature Coefficient

Thermal paper		Standard printing energy (mJ)	Temperature coefficient	
			25°C below	25°C or more
Nippon Paper	TF50KS-E2D	0.2258	0.003107	0.003107
	TP50KJ-R	0.2745	0.002950	0.002950
Oji Paper	PD160R-63	0.2276	0.002410	0.002410
	PD160R-N	0.2171	0.002746	0.002746
Mitsubishi Paper mills limited	P220VBB-1	0.2864	0.003028	0.003028
Jujo Thermal	AP50KS-D	0.2402	0.003685	0.003685
	AF50KS-E	0.2278	0.003540	0.003540
Mitsubishi Hi-Tech Paper	F5041	0.2576	0.002847	0.002847
Papierfabrik August Koehler AG	KT55F20	0.2895	0.003661	0.004859
KSP	P350	0.2462	0.002723	0.002723
KANZAN	KF50	0.2809	0.003006	0.003006

3.5.3 Adjustment of Thermal Head Resistance

The adjusted resistance “R” can be calculated using equation (5) to adjust the thermal head resistance as a voltage drop is caused by wiring resistance.

Equation (5):

$$R = \frac{(R_H + R_i + (R_C + r_c) \times N_{SA})^2}{R_H}$$

R_H	:	Thermal head heat element resistance	173.0 (Ω)
R_i	:	Wiring resistance in the thermal head	9 (Ω) ^{*1}
R_C	:	Common terminal wiring resistance in the thermal head	0.20 (Ω)
r_c	:	Wiring resistance between V_p and GND (Ω) ^{*2}	

*1 : V_{dd} is 5.0V. R_i is 13(Ω) if V_{dd} is 3.0 or 3.3V

*2 : The resistance is a serial resistance of the wire and switching circuit of relay between control terminal and power supply.

3.5.4 Adjustment of Thermal Head Drive Voltage

The adjusted voltage “V” can be calculated using equation (6) as the printing density changes by the difference of the thermal head drive voltage.

Equation (6):

$$V = 1.368 \times V_p - 2.800$$

3.5.5 Setting of Activation Pause Time

In order to protect the thermal head heat elements, when the same heat element dots are activated continuously on the successive dot line, determine the activation cycle (the time from the start of the preceding activation to the start of the current activation) which meets equation (7) to secure the pause time.

Equation (7):

$$W > t + 500(\mu s)$$

W : The activation cycle (μs)^{*}

*: The activation cycle W is the driving time of the printer drive motor for 2 steps (one-half dot line).

3.5.6 Adjustment by Thermal Head Activation Pulse Cycle

The thermal head activation pulse cycle coefficient “C” can be calculated using equations (8) as the printing density varies by the thermal head activation pulse cycle “W”.

Equation (8):

$$C = 1 - \frac{1020 \times V_p - 1650}{(V_p - 3.55) \times (W + 1350) + 1920}$$

3.5.7 Calculation Sample for the Activation Pulse Width

Table 3-13 lists the calculation samples of the activation pulse width calculated using equation (3) and the values obtained using equations (4) to (6) and (8).

Table 3-13 Activation Pulse Width

(1/2)
Unit : ms

VP [V]	TX [°C]	Motor drive frequency [pps]														
		400	600	800	1000	1200	1400	1600	1800	2000	2200	2400	2600	2800	3000	3200
4.75	-10	3.803	3.295	2.925	2.643	2.420	×	×	×	×	×	×	×	×	×	×
	0	3.450	2.989	2.653	2.397	2.196	×	×	×	×	×	×	×	×	×	×
	10	3.097	2.683	2.381	2.152	1.971	×	×	×	×	×	×	×	×	×	×
	20	2.744	2.377	2.110	1.906	1.746	×	×	×	×	×	×	×	×	×	×
	30	2.390	2.071	1.838	1.661	1.521	×	×	×	×	×	×	×	×	×	×
	40	2.037	1.765	1.567	1.415	1.296	×	×	×	×	×	×	×	×	×	×
	50	1.684	1.459	1.295	1.170	1.072	×	×	×	×	×	×	×	×	×	×
	60	1.331	1.153	1.023	0.925	0.847	×	×	×	×	×	×	×	×	×	×
	70	0.977	0.847	0.752	0.679	0.622	×	×	×	×	×	×	×	×	×	×
80	0.624	0.541	0.480	0.434	0.397	×	×	×	×	×	×	×	×	×	×	
5.5	-10	2.534	2.249	2.032	1.863	1.726	1.613	1.519	×	×	×	×	×	×	×	×
	0	2.299	2.040	1.844	1.690	1.566	1.463	1.378	×	×	×	×	×	×	×	×
	10	2.063	1.831	1.655	1.517	1.405	1.314	1.237	×	×	×	×	×	×	×	×
	20	1.828	1.622	1.466	1.344	1.245	1.164	1.096	×	×	×	×	×	×	×	×
	30	1.593	1.413	1.277	1.171	1.085	1.014	0.955	×	×	×	×	×	×	×	×
	40	1.357	1.205	1.089	0.998	0.924	0.864	0.814	×	×	×	×	×	×	×	×
	50	1.122	0.996	0.900	0.825	0.764	0.714	0.673	×	×	×	×	×	×	×	×
	60	0.887	0.787	0.711	0.652	0.604	0.564	0.532	×	×	×	×	×	×	×	×
	70	0.651	0.578	0.522	0.479	0.444	0.415	0.390	×	×	×	×	×	×	×	×
80	0.416	0.369	0.334	0.306	0.283	0.265	0.249	×	×	×	×	×	×	×	×	
6.0	-10	1.990	1.782	1.621	1.494	1.390	1.305	1.232	1.171	×	×	×	×	×	×	×
	0	1.805	1.616	1.471	1.355	1.261	1.183	1.118	1.062	×	×	×	×	×	×	×
	10	1.621	1.451	1.320	1.216	1.132	1.062	1.003	0.953	×	×	×	×	×	×	×
	20	1.436	1.285	1.170	1.078	1.003	0.941	0.889	0.844	×	×	×	×	×	×	×
	30	1.251	1.120	1.019	0.939	0.874	0.820	0.774	0.736	×	×	×	×	×	×	×
	40	1.066	0.954	0.868	0.800	0.745	0.699	0.660	0.627	×	×	×	×	×	×	×
	50	0.881	0.789	0.718	0.661	0.616	0.578	0.546	0.518	×	×	×	×	×	×	×
	60	0.696	0.623	0.567	0.523	0.486	0.456	0.431	0.410	×	×	×	×	×	×	×
	70	0.512	0.458	0.417	0.384	0.357	0.335	0.317	0.301	×	×	×	×	×	×	×
80	0.327	0.292	0.266	0.245	0.228	0.214	0.202	0.192	×	×	×	×	×	×	×	
7.2	-10	1.217	1.103	1.013	0.940	0.881	0.831	0.788	0.752	0.720	0.692	0.668	×	×	×	×
	0	1.104	1.000	0.919	0.853	0.799	0.754	0.715	0.682	0.653	0.628	0.606	×	×	×	×
	10	0.991	0.898	0.825	0.766	0.717	0.677	0.642	0.612	0.586	0.564	0.544	×	×	×	×
	20	0.878	0.795	0.731	0.678	0.635	0.599	0.569	0.542	0.520	0.499	0.482	×	×	×	×
	30	0.765	0.693	0.637	0.591	0.554	0.522	0.496	0.473	0.453	0.435	0.420	×	×	×	×
	40	0.652	0.591	0.542	0.504	0.472	0.445	0.422	0.403	0.386	0.371	0.358	×	×	×	×
	50	0.539	0.488	0.448	0.416	0.390	0.368	0.349	0.333	0.319	0.307	0.296	×	×	×	×
	60	0.426	0.386	0.354	0.329	0.308	0.291	0.276	0.263	0.252	0.242	0.234	×	×	×	×
	70	0.313	0.283	0.260	0.242	0.226	0.214	0.203	0.193	0.185	0.178	0.172	×	×	×	×
80	0.200	0.181	0.166	0.154	0.145	0.136	0.129	0.123	0.118	0.114	0.110	×	×	×	×	
8.0	-10	0.925	0.842	0.776	0.723	0.679	0.642	0.610	0.583	0.559	0.538	0.520	0.503	0.488	×	×
	0	0.839	0.764	0.704	0.656	0.616	0.582	0.554	0.529	0.507	0.488	0.471	0.456	0.443	×	×
	10	0.753	0.686	0.632	0.589	0.553	0.523	0.497	0.475	0.455	0.438	0.423	0.410	0.397	×	×
	20	0.667	0.607	0.560	0.522	0.490	0.463	0.440	0.420	0.403	0.388	0.375	0.363	0.352	×	×
	30	0.581	0.529	0.488	0.454	0.427	0.403	0.384	0.366	0.351	0.338	0.327	0.316	0.307	×	×
	40	0.495	0.451	0.416	0.387	0.364	0.344	0.327	0.312	0.299	0.288	0.278	0.269	0.261	×	×
	50	0.410	0.373	0.344	0.320	0.301	0.284	0.270	0.258	0.248	0.238	0.230	0.223	0.216	×	×
	60	0.324	0.295	0.272	0.253	0.238	0.225	0.214	0.204	0.196	0.188	0.182	0.176	0.171	×	×
	70	0.238	0.216	0.200	0.186	0.175	0.165	0.157	0.150	0.144	0.138	0.134	0.129	0.125	×	×
80	0.152	0.138	0.127	0.119	0.111	0.105	0.100	0.096	0.092	0.088	0.085	0.083	0.080	×	×	

V _P [V]	T _X [°C]	Motor drive frequency [pps]														
		400	600	800	1000	1200	1400	1600	1800	2000	2200	2400	2600	2800	3000	3200
8.5	-10	0.792	0.723	0.668	0.623	0.586	0.554	0.527	0.504	0.484	0.466	0.450	0.436	0.423	0.412	0.401
	0	0.719	0.656	0.606	0.565	0.531	0.503	0.478	0.457	0.439	0.423	0.408	0.395	0.384	0.373	0.364
	10	0.645	0.589	0.544	0.507	0.477	0.451	0.429	0.410	0.394	0.379	0.366	0.355	0.345	0.335	0.327
	20	0.572	0.522	0.482	0.449	0.422	0.400	0.380	0.364	0.349	0.336	0.325	0.314	0.305	0.297	0.289
	30	0.498	0.454	0.420	0.391	0.368	0.348	0.331	0.317	0.304	0.293	0.283	0.274	0.266	0.259	0.252
	40	0.424	0.387	0.358	0.334	0.314	0.297	0.282	0.270	0.259	0.250	0.241	0.233	0.227	0.221	0.215
	50	0.351	0.320	0.296	0.276	0.259	0.245	0.233	0.223	0.214	0.206	0.199	0.193	0.187	0.182	0.178
	60	0.277	0.253	0.234	0.218	0.205	0.194	0.184	0.176	0.169	0.163	0.157	0.153	0.148	0.144	0.140
	70	0.204	0.186	0.172	0.160	0.151	0.142	0.136	0.130	0.124	0.120	0.116	0.112	0.109	0.106	0.103
	80	0.130	0.119	0.110	0.102	0.096	0.091	0.087	0.083	0.079	0.076	0.074	0.072	0.069	0.068	0.066
9.5	-10	0.600	0.549	0.509	0.476	0.448	0.425	0.405	0.387	0.372	0.359	0.347	0.336	0.326	0.318	0.310
	0	0.544	0.498	0.462	0.431	0.406	0.385	0.367	0.351	0.337	0.325	0.315	0.305	0.296	0.288	0.281
	10	0.489	0.447	0.414	0.387	0.365	0.346	0.329	0.315	0.303	0.292	0.282	0.274	0.266	0.259	0.252
	20	0.433	0.396	0.367	0.343	0.323	0.306	0.292	0.279	0.268	0.259	0.250	0.242	0.236	0.229	0.224
	30	0.377	0.345	0.320	0.299	0.282	0.267	0.254	0.243	0.234	0.225	0.218	0.211	0.205	0.200	0.195
	40	0.321	0.294	0.273	0.255	0.240	0.227	0.217	0.207	0.199	0.192	0.186	0.180	0.175	0.170	0.166
	50	0.266	0.243	0.225	0.211	0.198	0.188	0.179	0.171	0.165	0.159	0.154	0.149	0.145	0.141	0.137
	60	0.210	0.192	0.178	0.166	0.157	0.149	0.142	0.135	0.130	0.125	0.121	0.118	0.114	0.111	0.108
	70	0.154	0.141	0.131	0.122	0.115	0.109	0.104	0.100	0.096	0.092	0.089	0.086	0.084	0.082	0.080
	80	0.098	0.090	0.084	0.078	0.074	0.070	0.066	0.064	0.061	0.059	0.057	0.055	0.054	0.052	0.051

× : Unusable

- * : The table above is applicable under the following condition:
- Use of thermal paper "TF50KS-E2D"
 - V_p and GND wiring resistance : r_c = 0
 - The number of simultaneously activated dots : N = 96

3.5.8 Temperature Characteristics of the Thermistor

Calculate the resistance of the thermistor (R_x) at the operating temperature T_x ($^{\circ}\text{C}$) using the following equation (9). Variation of resistance by temperature is shown in Figure 3-9 and Table 3-14.

Equation (9):

$$R_x = R_{25} \times \text{EXP} \left\{ B \times \left(\frac{1}{273 + T_x} - \frac{1}{298} \right) \right\}$$

- R_x : Resistance at T_x $^{\circ}\text{C}$ (Ω)
- R_{25} : Resistance at 25 $^{\circ}\text{C}$ $30 \pm 5\%$ (k Ω)
- B : B value $3950 \pm 2\%$ (K)
- EXP (A) : The "A" th power of natural logarithm e (2.71828)

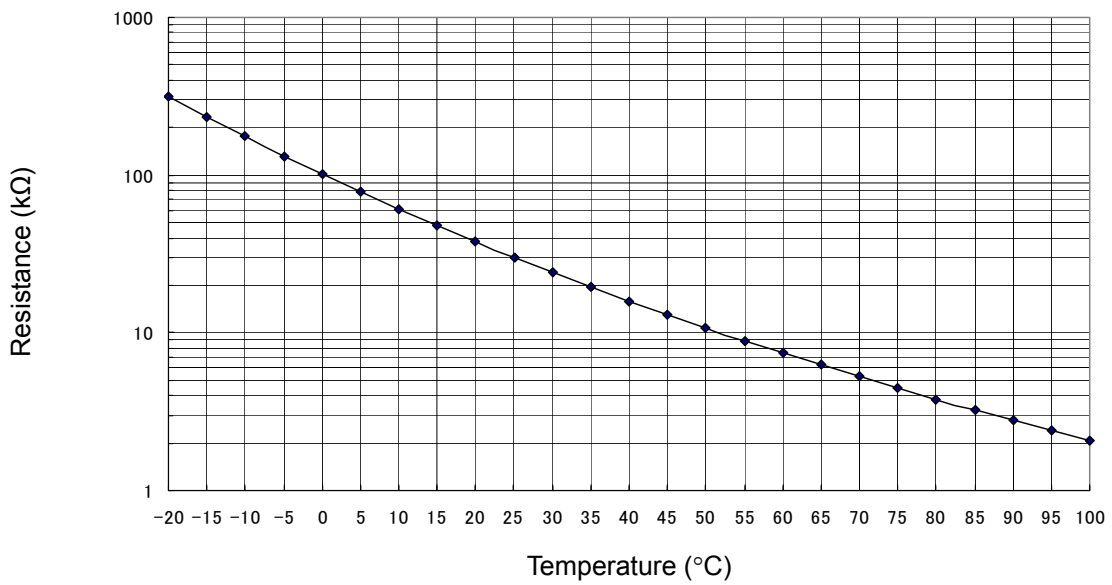

Figure 3-9 Temperature Characteristics of the Thermistor

Table 3-14 Temperature Characteristics of the Thermistor

Temperature (°C)	Thermistor Resistance (kΩ)
-20	316.97
-15	234.22
-10	175.07
-5	132.29
0	100.99
5	77.85
10	60.57
15	47.53
20	37.61
25	30.00
30	24.11
35	19.51
40	15.89
45	13.03
50	10.75
55	8.92
60	7.45
65	6.25
70	5.27
75	4.47
80	3.80
85	3.25
90	2.79
95	2.41
100	2.09

3.5.9 Detecting Abnormal Temperature of the Thermal Head

To protect the thermal head and to ensure personal safety, abnormal temperature of the thermal head must be detected by both hardware and software as follows:

(1) Detecting abnormal temperatures by software

Design software that will deactivate the heat elements if the thermal head thermistor (TH) detects a temperature higher than 80°C (thermistor resistance $R_{TH} \leq 3.80 \text{ k}\Omega$), and reactivate the heat elements when a temperature lower than 60°C ($R_{TH} \geq 7.45 \text{ k}\Omega$) is detected. If the thermal head continues to be activated at a temperature higher than 80°C, the life of the thermal head may be shortened significantly.

(2) Detecting abnormal temperatures by hardware

If the thermal head continues to be activated by malfunction of the control unit (CPU), the software for detecting abnormal temperatures may not function properly, resulting in overheating of the thermal head. Overheating of the thermal head not only may damage the thermal head but also may cause smoke, fire and burn injuries. Always use hardware together with software for detecting abnormal temperatures to ensure personal safety. (If the control unit malfunctions, it may be impossible to prevent damage on the thermal head even if an abnormal temperature is detected by hardware.).

Using a window comparator circuit or similar sensor, design hardware that detects the following abnormal conditions:

- (a) Overheating of the thermal head
(approximately 100°C or higher ($R_{TH} \leq 2.09 \text{ k}\Omega$))
- (b) Faulty thermistor connection (the thermistor may be open or short-circuited).

If abnormal condition is detected, immediately turn off the power supply. Reactivate the heat elements after they have returned to normal.

3.6 THERMAL PAPER CUTTING CONDITIONS

The autocutter of this printer can select the method to cut the thermal paper in full cut or partial cut (tab left at the center) by changing the number of driving steps for autocutter drive motor.

Full cut :	610 steps
Partial cut :	534 steps

Figure 3-10 shows the full cutting method and the partial cutting method for the thermal paper.

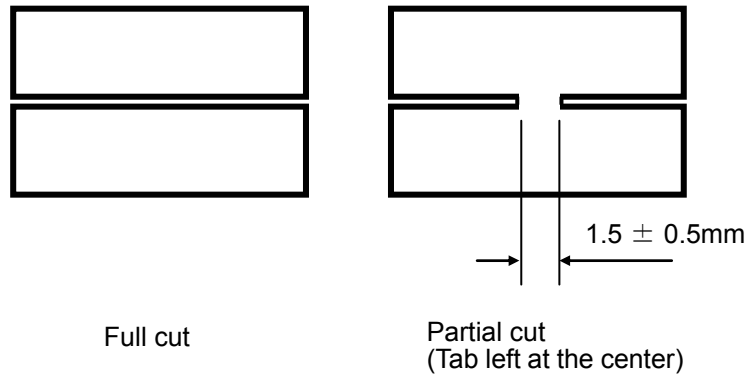

Figure 3-10 Thermal Paper Cut Condition

3.7 STEP MOTOR (AUTOCUTTER DRIVE MOTOR)

3.7.1 General Specifications

Table 3-15 shows general specifications of the step motor.

Table 3-15 General Specifications of the Step Motor

Item	Specifications
Type	PM type step motor
Drive method	Bi-polar chopper
Excitation method	1-2 phase
Winding resistance per phase	12 Ω / phase ± 10%
Motor drive voltage	V _P :4.75 to 9.5V
Motor controlled current	300mA/ phase
Drive pulse rate	1255pps max.(Outward) 2242pps max.(Homeward)

3.7.2 Sample Drive Circuit

Figure 3-11a shows the sample drive circuit 1, when the current is controlled with VREF of the motor driver output. (using the D/A converter etc.)

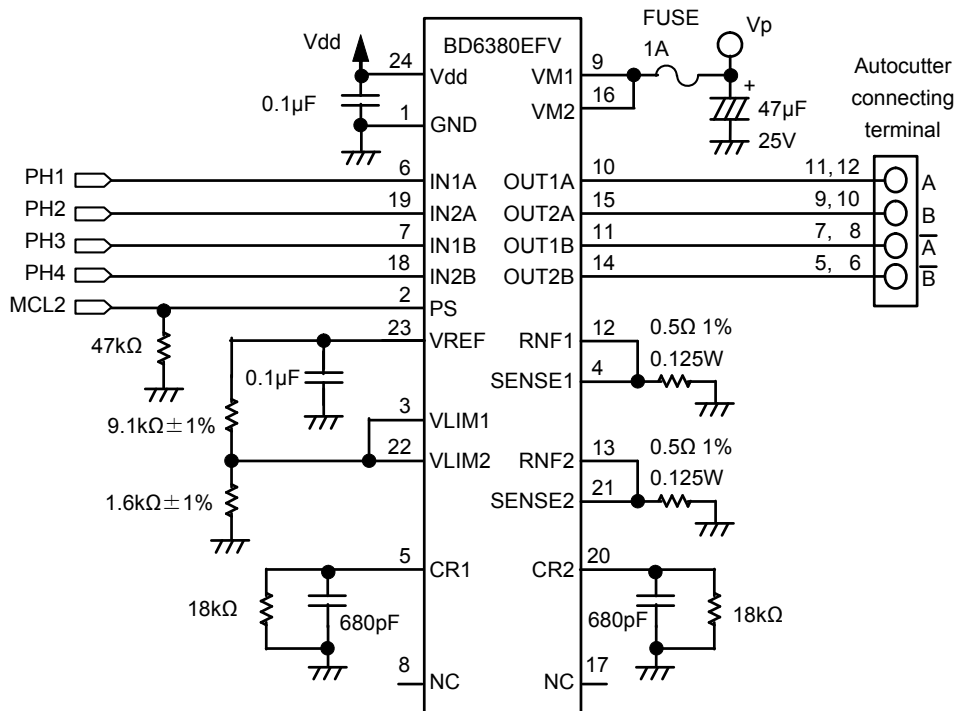

*: Recommended motor driver : BD6380EFV (ROHM)

Figure 3-11a Sample Drive Circuit 1

Figure 3-11b shows the sample drive circuit 2, when the current is controlled without VREF of the motor driver output. (using the D/A converter etc.)

- **MREF signal**

It is the reference signal for the motor current control. The motor drive setting current is set by the MREF signal setting voltage.

CAPD245 Autocutter drive (300mA) : $150\text{mV} \pm 5\%$

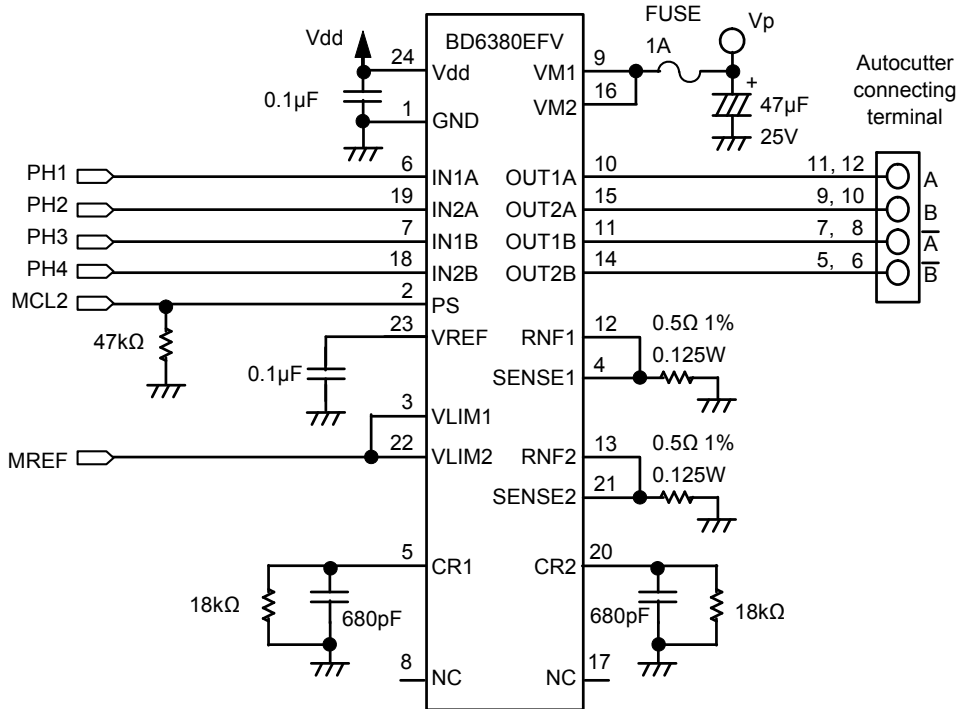

*: Recommended motor driver : BD6380EFV (ROHM)

Figure 3-11b Sample Drive Circuit 2

3.7.3 Excitation Sequence

Drive the motor with 1-2 phase excitation. The voltage wave forms shown in Figure 3-12a put to the motor drive circuit shown in Figure 3-11, the motor drives in the normal rotation, the movable blade is moved to the fixed blade direction (Outward) and cut the thermal paper when the motor is excited in order of step 1, step 2, step 3, step 4, step 5, step 6, step7, step 8, step 1, step 2, , as shown in Table 3-16.

The voltage wave forms shown in Figure 3-12b put to the motor drive circuit shown in Figure 3-11 the motor is rotated in the reverse direction, the movable blade is moved to the home position direction (Homeward) when the motor is excited in order of step 1, step 8, step 7, step 6, step 5, step 4, step 3, step 2, step 1, step 8, , as shown in Table 3-16.

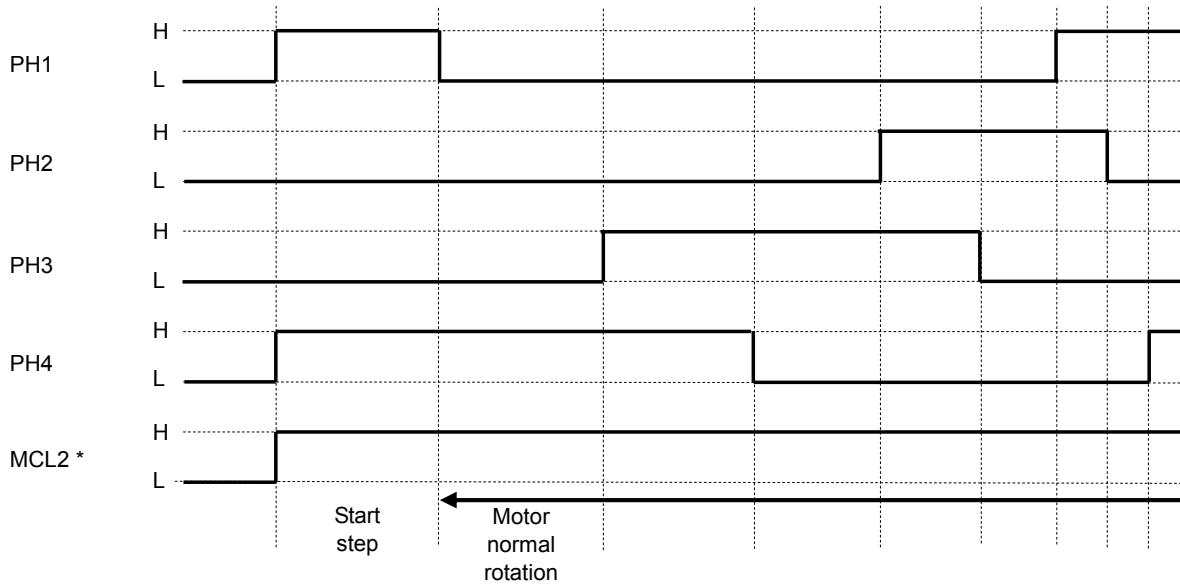

*: Set MCL2 to "High" while the motor is driven.

Figure 3-12a Input Voltage Waveforms for the Sample Drive Circuit (Outward)

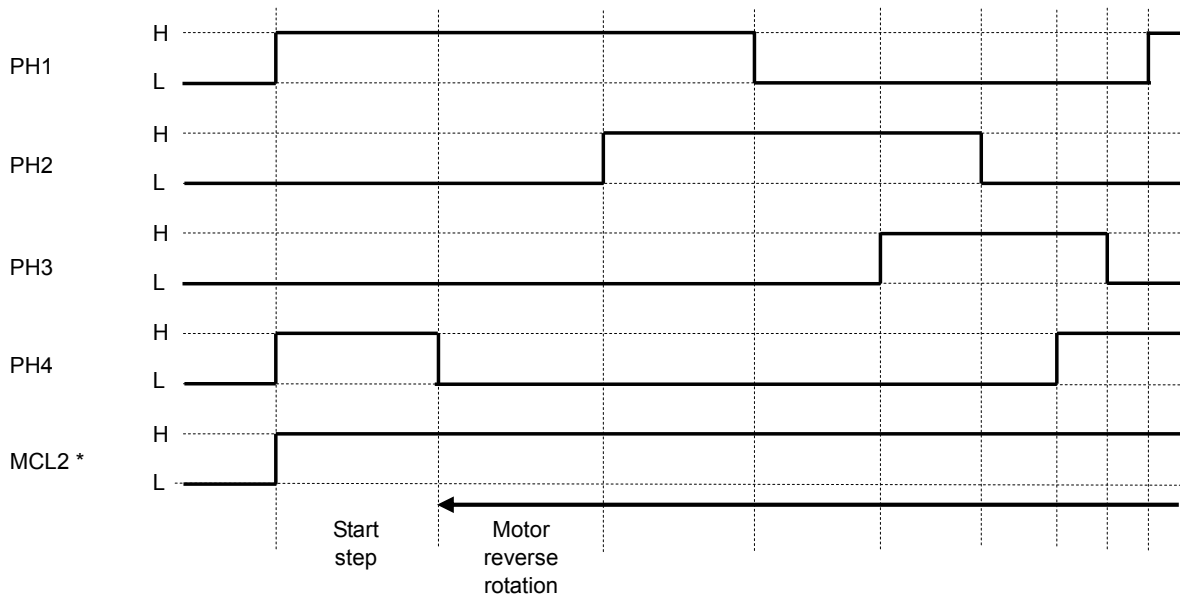

*: Set MCL2 to "High" while the motor is driven.

Figure 3-12b Input Voltage Waveforms for the Sample Drive Circuit (Homeward)

Table 3-16 Excitation Sequence

	Input signal				Output signal			
	PH1	PH2	PH3	PH4	A	B	\bar{A}	\bar{B}
Step 1	H	L	L	H	H	L	L	H
Step 2	L	L	L	H	OPEN	L	OPEN	H
Step 3	L	L	H	H	L	L	H	H
Step 4	L	L	H	L	L	OPEN	H	OPEN
Step 5	L	H	H	L	L	H	H	L
Step 6	L	H	L	L	OPEN	H	OPEN	L
Step 7	H	H	L	L	H	H	L	L
Step 8	H	L	L	L	H	OPEN	L	OPEN

3.7.4 Autocutter Drive Motor Start/Stop Method

Design the control circuit and software to stop/start for autocutter drive motor, refer Figure 3-13 Timing Chart.

(1) Start step

To start the motor from the pause (no excitation) state, shift the motor to the sequence of cut step after exciting the same phase as that of the stop step for the first acceleration step time of the acceleration step.

(2) Stop step

To stop the motor, excite the same phase as the last one in the cut step for 20ms.

However, the last cut step is one phase excitation, add one step of the cut step and excite the pause state is two phase excitation.

(3) Pause state

In the pause state, do not excite the motor to prevent to the motor from overheating.

The voltage wave forms of the sample drive circuit is shown in Figure 3-13.

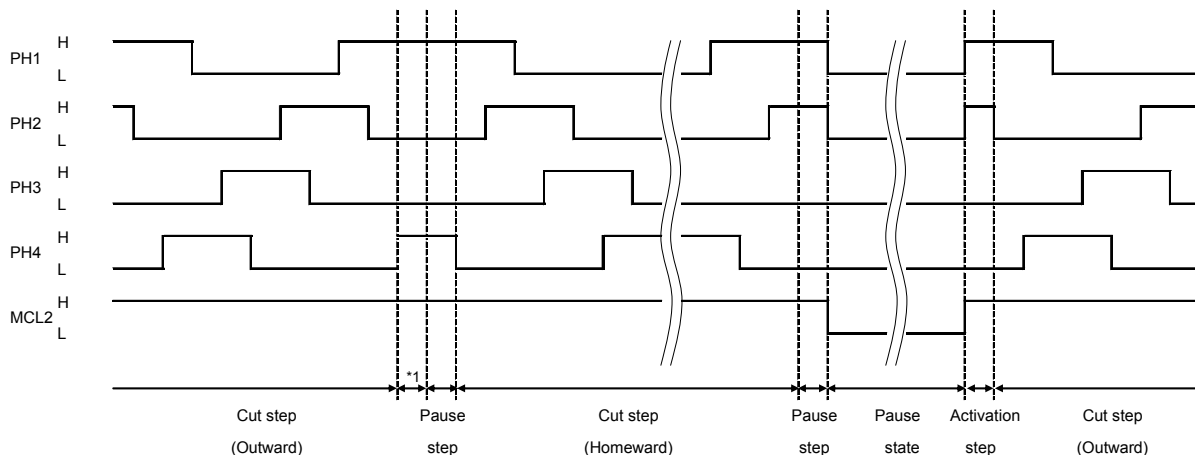

*1 : The last cut step is one phase excitation, so add one step of the cut step.

Figure 3-13 Autocutter Drive Motor Start/Stop Timing Chart

3.7.5 Autocutter Drive Motor Drive Method

To drive the autocutter drive motor, follow the method below.

(1) Drive frequency

The motor is normal rotation (Outward) : 1255pps max.
The motor is reverse rotation (Homeward) : 2242pps max.

(2) Speed control

When driving the motor, the acceleration control is required. If acceleration of the motor does not perform correctly, the motor may step out. Accelerate the speed sequentially up to the maximum motor drive pulse rate P_M according to the Table 3-5 Acceleration Steps (CAPD245).

Acceleration should be performed by the acceleration step time below, that is output the phase.

1. Drive the start step as same as acceleration step time at Start acceleration step.
2. Drive the first step as same as acceleration step time at 1st acceleration step.
3. Drive the second step as same as acceleration step time at 2nd acceleration step.
4. Hereinafter, drive the "n"th step as same as acceleration step time at "n"th acceleration step.
5. After accelerating up to the maximum motor drive pulse rate P_M , drive the motor at a constant speed.

(3) Preventing overheat

It is possible to drive the autocutter drive motor continuously, within the specifications.

Temperature rise of the motor is different according to the use conditions. (ambient temperature, designing the outer case etc.) Keep the temperature of the motor outer case, 100°C or lower. Verify the performance with your actual device.

3.7.6 Precaution of the Autocutter Drive Motor

- It cannot give the specified performance, if using except 3.7.2 Sample Drive Circuit.
- Do not drive the autocutter drive motor while the printer drive motor is driving. It may cause of damage.

3.8 OUT-OF-PAPER SENSOR

The printer has a built-in out-of-paper sensor (reflection type photo interrupter) to detect whether the thermal paper is present or not. The external circuit should be designed so that it detects output from the out-of-paper sensor and does not activate the thermal head, the printer drive motor and the autocutter drive motor when there is no paper.

Doing so may cause damage to the thermal head or platen, shorten the life of the thermal head significantly.

The printer drive motor is driven when there is no paper, a load is put on the paper drive system and the life of the printer may be shortened significantly.

The autocutter drive motor is driven when there is no paper, the life of the autocutter may be shortened significantly.

Table 3-17 shows about the out-of-paper sensor used for this printer.

Table 3-17 Out-of-paper Sensor

Item	Specification
Type	NJL5902R (Rank B)
Manufacturer	New Japan Radio Co.,Ltd.

Figure 3-14 shows sample external circuit of the out-of-paper sensor.

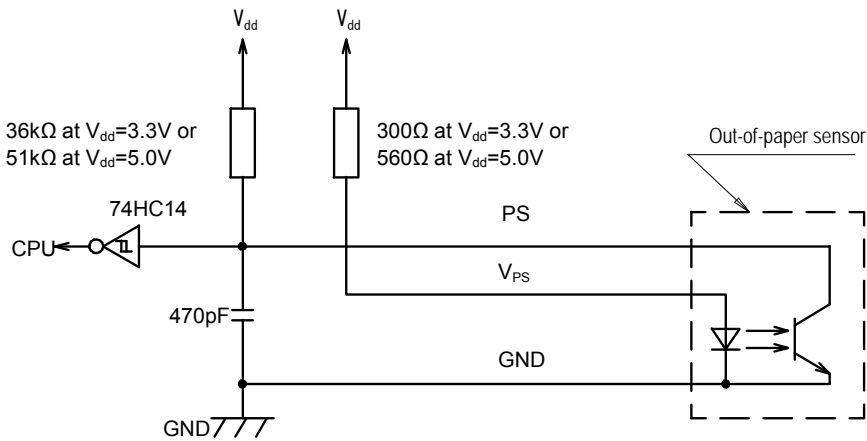

*: The PS signal is "High" when there is no paper.

Figure 3-14 Sample External Circuit of the Out-of-paper Sensor

3.9 PLATEN POSITION SENSOR

The printer has a built-in platen position sensor for detecting the platen block is set or opened. This sensor is a mechanical switch which is designed to be ON when the platen block is set and to be OFF when it is opened.

The external circuit should be designed so that it detects output from the platen position sensor and does not activate the thermal head, the printer drive motor and the autocutter drive motor when the platen block is in open state. Otherwise, the thermal head may become damaged or its life may be shortened significantly.

The printer drive motor is driven when the platen block is in open state, the hair may get caught in the drive gears.

The autocutter drive motor is driven when the platen block is in open state, it is dangerous the users can touch the movable blade directly.

3.9.1 General Specifications

Table 3-18 shows about the general specification

Table 3-18 General Specifications of the Platen Position Sensor

Item	Specification
Rated voltage	DC5.0V
Rated current	1mA
Contact resistance	3Ω max.

Figure 3-15 shows sample external circuit of the platen position sensor.

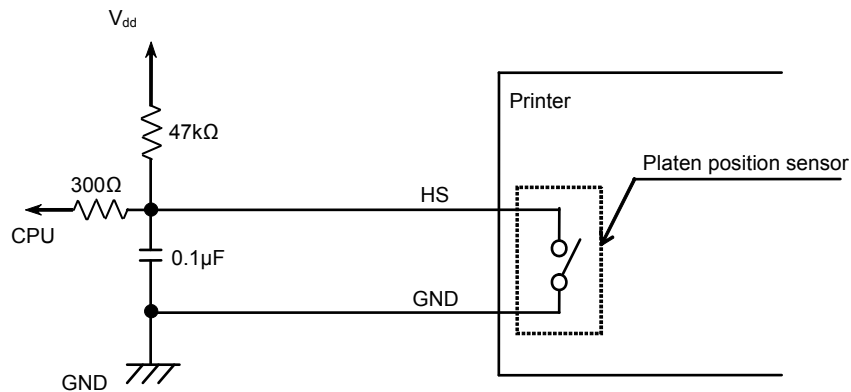

*: The HS signal is "High" when the platen is in open state.

Figure 3-15 Sample External Circuit of the Platen Position Sensor

3.9.2 Platen Position Sensor Precautions

- Be sure that there is a time lag between the time when the thermal head is set and the platen position sensor actually starts detecting.
- Always use the capacitor shown in Figure 3-15 to prevent the switch from malfunctioning due to chattering.

3.10 CUTTER HOME POSITION SENSOR

The printer has a built-in cutter home position sensor (transmissive type photo interrupter) for detecting the position of the movable blade. The external circuit should be designed so that the cutter home position sensor detects where the movable blade is and it will not drive the motor unless the movable blade is in its home position.

If the movable blade is driven out of the home position, it occurs the paper jam or damaged for the movable blade.

Table 3-19 shows the specifications of the cutter home position sensor.

Table 3-19 Cutter Home Position Sensor

Item	Specification
Type	GP1S092HCPIF
Manufacturer	Sharp Corporation

Figure 3-16 shows the sample external circuit of the cutter home position sensor.

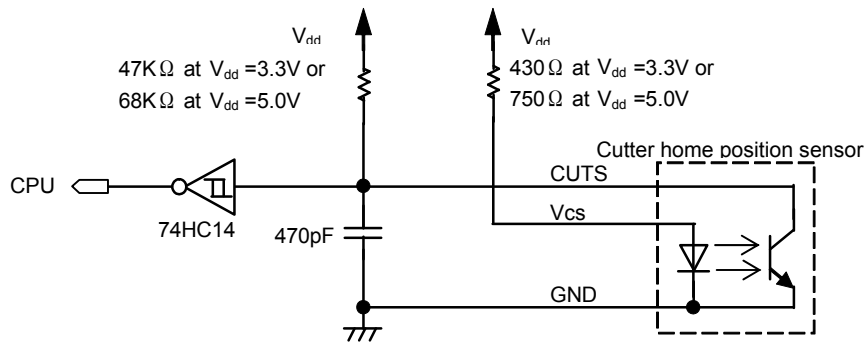

*: The CUTS signal is "High" when the movable blade is in its home position.

Figure 3-16 Sample External Circuit of the Cutter Home Position Sensor

CHAPTER 4 CONNECTING TERMINALS

4.1 RECOMMENDED CONNECTOR FOR EXTERNAL CIRCUITS

Use the recommended connectors listed in Table 4-1 to connect the printer connecting terminals firmly to the external circuits.

Table 4-1 Recommended Connectors

No.	Connector for External Circuits	Number of Terminals	Recommended Connectors
1	Printer connecting terminals (FPC)	50	MOLEX INC : 0541045031 (right angle type, top contact, gold plated)
2	Autocutter connecting terminals (FPC)	12	MOLEX INC : 0545501271 (right angle type, top contact, gold plated)

4.2 PRINTER CONNECTING TERMINALS

Figure 4-1 shows the terminal configuration of the printer connecting terminals and Table 4-2 shows terminal assignments of the printer connecting terminals.

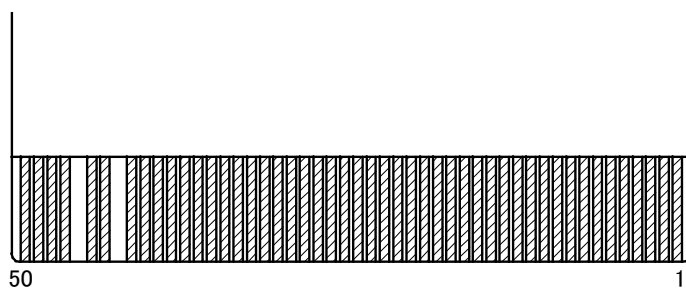

Figure 4-1 Printer Connecting Terminals

Table 4-2 Terminal Assignments of the Printer Connecting Terminal (CAPD245)

(1/2)

Terminal No.	Signal Name	Function
1	V _P	Thermal head drive power supply
2	V _P	Thermal head drive power supply
3	V _P	Thermal head drive power supply
4	V _P	Thermal head drive power supply
5	V _P	Thermal head drive power supply
6	V _P	Thermal head drive power supply
7	DI	Print data input (serial input)
8	CLK	Synchronizing signal for print data transfer
9	GND	GND
10	GND	GND
11	GND	GND
12	GND	GND
13	GND	GND
14	GND	GND
15	DST6	Thermal head print activation instruction signal (#6 block)
16	DST5	Thermal head print activation instruction signal (#5 block)
17	DST4	Thermal head print activation instruction signal (#4 block)
18	V _{dd}	Logic power supply
19	TH2	Thermistor (Connecting to GND and use)
20	TH1	Thermistor (same as terminal No.21)
21	TH1	Thermistor (same as terminal No.20)
22	DST3	Thermal head print activation instruction signal (#3 block)
23	DST2	Thermal head print activation instruction signal (#2 block)
24	DST1	Thermal head print activation instruction signal (#1 block)
25	GND	GND
26	GND	GND
27	GND	GND
28	GND	GND
29	GND	GND
30	GND	GND

Terminal No.	Signal Name	Function
31	$\overline{\text{LAT}}$	Print data latch (memory storage) signal
32	V_P	Thermal head drive power supply
33	V_P	Thermal head drive power supply
34	V_P	Thermal head drive power supply
35	V_P	Thermal head drive power supply
36	V_P	Thermal head drive power supply
37	V_P	Thermal head drive power supply
38	N.C.	No connection
39	PS	Output signal of the out-of-paper sensor (Photo-transistor collector)
40	V_{PS}	Power supply of the out-of-paper sensor (LED anode)
41	GND	GND of the out-of-paper sensor (LED cathode, photo-transistor emitter) Platen position sensor GND
42	HS	Platen position sensor output
43	N.C.	No connection
44	FG	FG
45	FG	FG
46	N.C.	No connection
47	\overline{A}	Printer drive motor drive signal
48	B	Printer drive motor drive signal
49	A	Printer drive motor drive signal
50	\overline{B}	Printer drive motor drive signal

4.3 AUTOCUTTER CONNECTING TERMINALS

Figure 4-2 shows the terminal configuration of the autocutter connecting terminals and Table 4-3 shows terminal assignments of the autocutter connecting terminals.

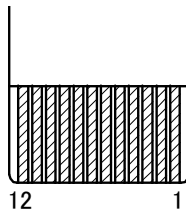

Figure 4-2 Autocutter Connecting Terminals

Table 4-3 Terminal Assignments of the Autocutter Connecting Terminal

Terminal Number	Signal Name	Function
1	N.C.	No connection
2	V_{CS}	Power supply of the cutter home position sensor (LED anode)
3	GND	GND of the cutter home position sensor (LED cathode, photo-transistor emitter)
4	CUTS	Output signal of the cutter home position sensor (Photo-transistor collector)
5	\bar{B}	Autocutter drive motor drive signal
6	\bar{B}	Autocutter drive motor drive signal
7	\bar{A}	Autocutter drive motor drive signal
8	\bar{A}	Autocutter drive motor drive signal
9	B	Autocutter drive motor drive signal
10	B	Autocutter drive motor drive signal
11	A	Autocutter drive motor drive signal
12	A	Autocutter drive motor drive signal

CHAPTER 5

DRIVE METHOD

5.1 PRINT DRIVE METHOD

5.1.1 Printer Drive Motor and Thermal Head Drive Method

The printer drive motor and the thermal head must be driven at the same time for printing.

The printer has half dot pitch thermal head, the pitch to the paper feed direction is one-half dot of the heat elements. Configure 1 dot by 2 half dots.

The motor feeds the thermal paper for 1 dot line by the 4 steps. It is necessary to feed the thermal paper 4 steps and activate the thermal head once every 2 steps, for configure 1 dot line.

At the 1st step of the motor drive signal, start activation of the thermal head by synchronized the DST1 signal and printing the 1st half dot line at the 1st dot line by DST1 to DST6.

The example of the CAPD245 driving is shown below.

Figure 5-1 shows a timing chart for using fixed six divisions printing.

Figure 5-2 shows a timing chart for using batch printing.

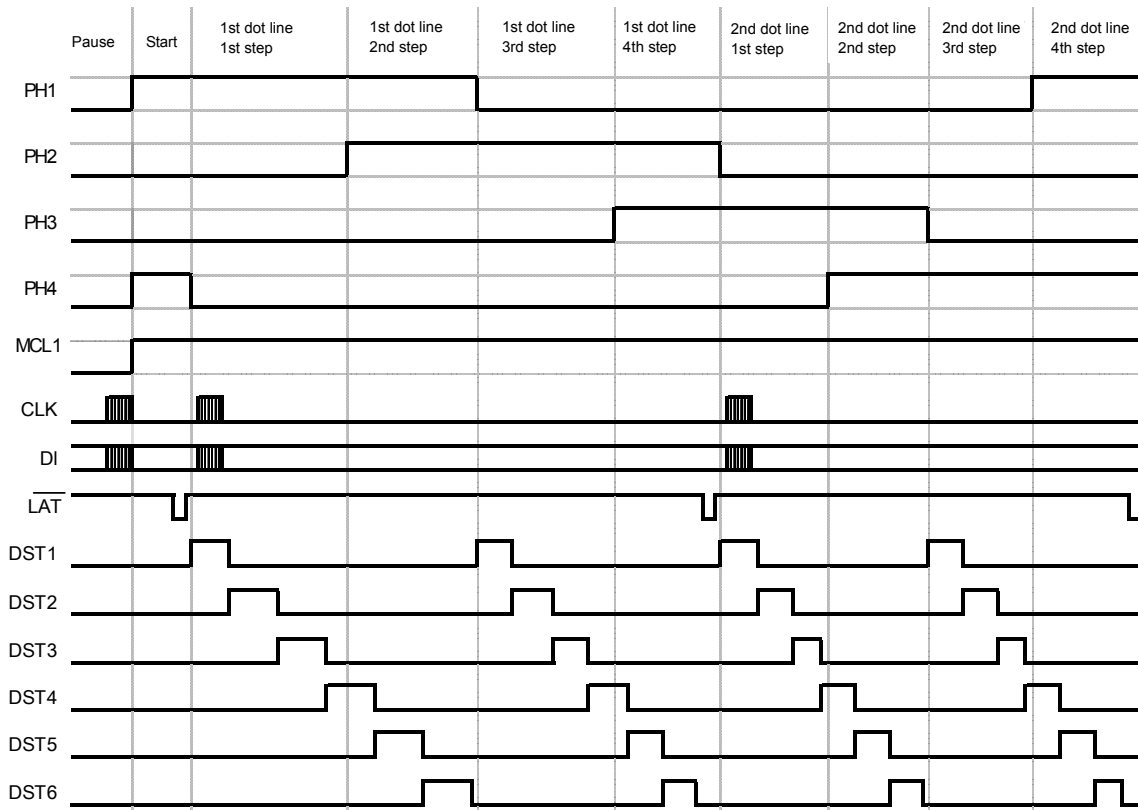

Figure 5-1 Timing Chart for Using Fixed Six Divisions Printing (CAPD245)

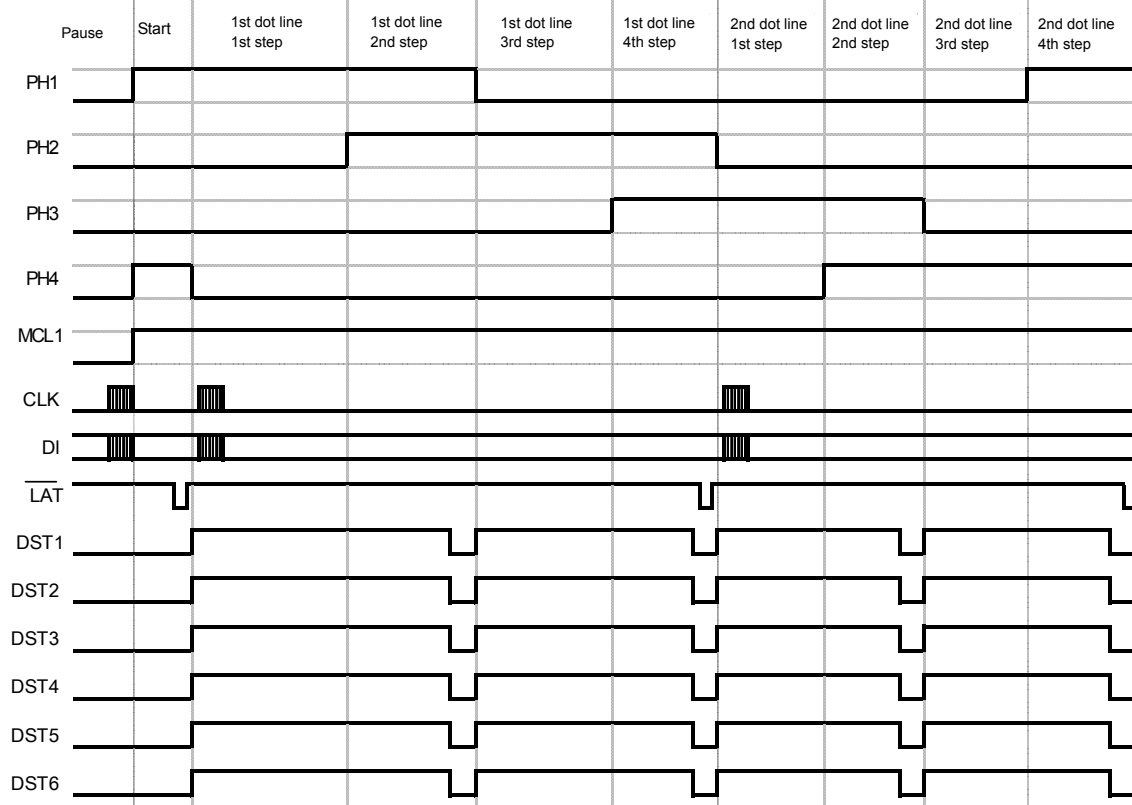

Figure 5-2 Timing Chart for Using Batch Printing (CAPD245)

The drive method using fixed six divisions is explained below (See Figure 5-1):

(1) Pause state

Inactivate the motor and always make DST signal of the thermal head "Low".

(2) Start step

Excite the motor by the same phase which is output just before the motor stops.

(3) 1st dot line

Activate the thermal head once every 2 steps of the motor drive signal. Configure 1 dot line by 4 steps of the motor drive signal.

At the 1st step of the motor drive signal, start activation of the thermal head by synchronized the DST1 signal and printing the 1st half dot line at the 1st dot line by DST1 to DST6.

After 1 step of the motor drive signal is completed, input the 2nd step of the motor drive signal. (It is not necessary to synchronize the activation of the thermal head.)

After printing the 1st half dot line at the 1st dot line, the 3rd step of the motor drive signal, start activation of the thermal head by synchronized the DST1 signal and printing the 2nd half dot line at the 1st dot line by DST1 to DST6.

After 3 step of the motor drive signal is completed, input the 4th step of the motor drive signal. (It is not necessary to synchronize the activation of the thermal head.)

Input the DST signal previously, transfer the data which is printed into the "SHIFT REGISTER" in the thermal head. And latch to "LATCH REGISTER" of the thermal head by inputting the \overline{LAT} signal.

(4) Procedures that follows the 2nd dot line

Drive the motor in the same way as the 1st dot line. Repeat the motor driving and thermal head activation.

5.1.2 Thermal Head Division Drive Method

In the thermal head of the printer, there are 6 blocks (every 64 dots) in 1 dot line for CAPD245. These blocks are called physical blocks. DST signal is allocated to each physical block to activate it. To drive the thermal head, physical blocks are activated in groups. The group of physical blocks is called a logical block.

The following two methods are available as thermal head division drive methods. Select one you desire.

(1) Fixed division method

Logical blocks (physical blocks to be driven at the same time) are predetermined for the fixed division method.

In this method, high quality printing is available because the physical blocks are always driven in the same order.

(2) Dynamic division method

Logical blocks are predetermined so that number of dots of the physical block does not exceed the specified maximum number of the activating dots for every 1 dot line printing. Logical blocks are predetermined for every 1 dot line printing.

The maximum current consumption can be controlled within a constant value.

Since the order of the printing block and print speed are changed in each dot line according to the content of the print data, print quality in this method may be lower than that in fixed division method. If print quality is regarded as important, printing in fixed division method is recommended.

5.1.3 Precautions for Print Drive

- The activation time of the thermal head can be longer than the motor step time depending on the type of the thermal paper, content of the printing and use conditions. In that case, the 1st step time and the 2nd step time of the half dot line, divide equally of the thermal head activation time.
- When using batch printing for physical blocks, a pause time between thermal head activations of the same heat element shall be secured more than 0.5ms.
- The number of the maximum thermal head division in 1 dot line should be 6 or less to maintain print quality. The number of the simultaneously activated dots should be 96 dots or less.

5.2 AUTOCUTTER DRIVE METHOD

5.2.1 Timing Chart for Autocutter Drive

Change the speed according to the timing chart shown in Figure 5-3. Follow the acceleration steps of autocutter drive motor which is shown in Table 3-5 of Chapter 3, and accelerate to the maximum motor drive frequency in order.

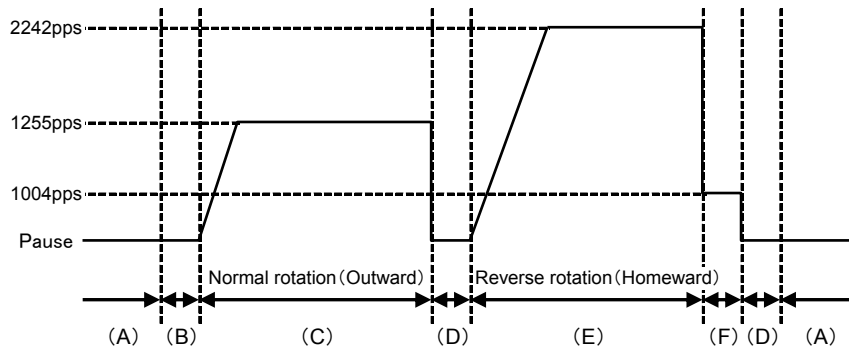

Figure 5-3 Timing Chart for Autocutter Drive (CAPD245)

(A) Pause state

Inactivate the motor.

(B) Start step

Excite the motor by the same phase which is output just before the motor stops. Perform the start step by the 2 phase excitation condition.

(C) Cut performance step (Outward)

Perform the acceleration control till maximum motor drive frequency of the outward, and drive the motor (normal rotation) according to the cut condition. (Full cut / Partial cut)

Full cut :	610 steps
Partial cut :	534 steps

(D) Stop step

Perform the stop step by the 2 phase excitation condition. Excite the stop step for 20ms.

(E) Cut performance step (Homeward)

Perform the acceleration control till maximum motor drive frequency of the homeward, and drive (reverse rotation) for the motor.

(F) Cutter home position detecting step

Detects CUTS="High", and drive (reverse rotation) 30steps by 1004pps of the motor drive frequency.

(D) Stop step

Input 20ms for stop step.

5.2.2 Flow Chart for Autocutter Drive

(1) Initializing performance

When turn the power on or after release the error, perform the initializing performance to return the movable blade to the home position. The flow chart of initializing performance is shown in Figure 5-4.

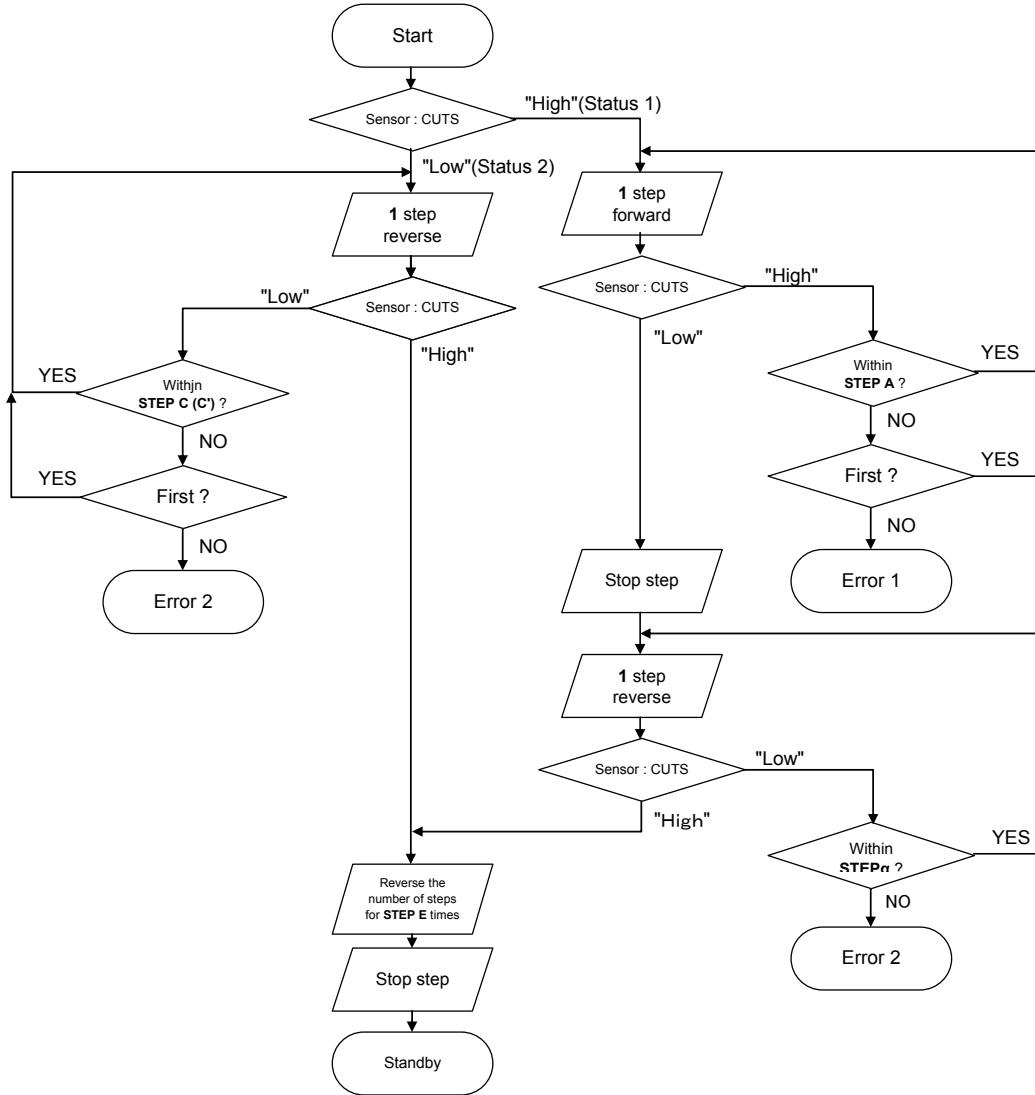

Error 1 : It is possible that the printer mechanism failure or the poor connection is occurred.

Error 2 : It is possible that the cutter error is occurred. Refer to Chapter 8 "INSTALLING/UNINSTALLING THE THERMAL PAPER" for releasing method when the cutter error is occurred.

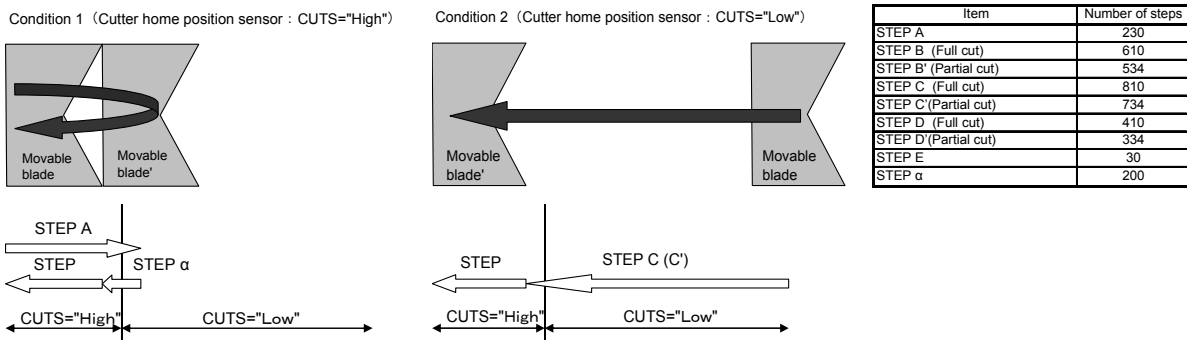
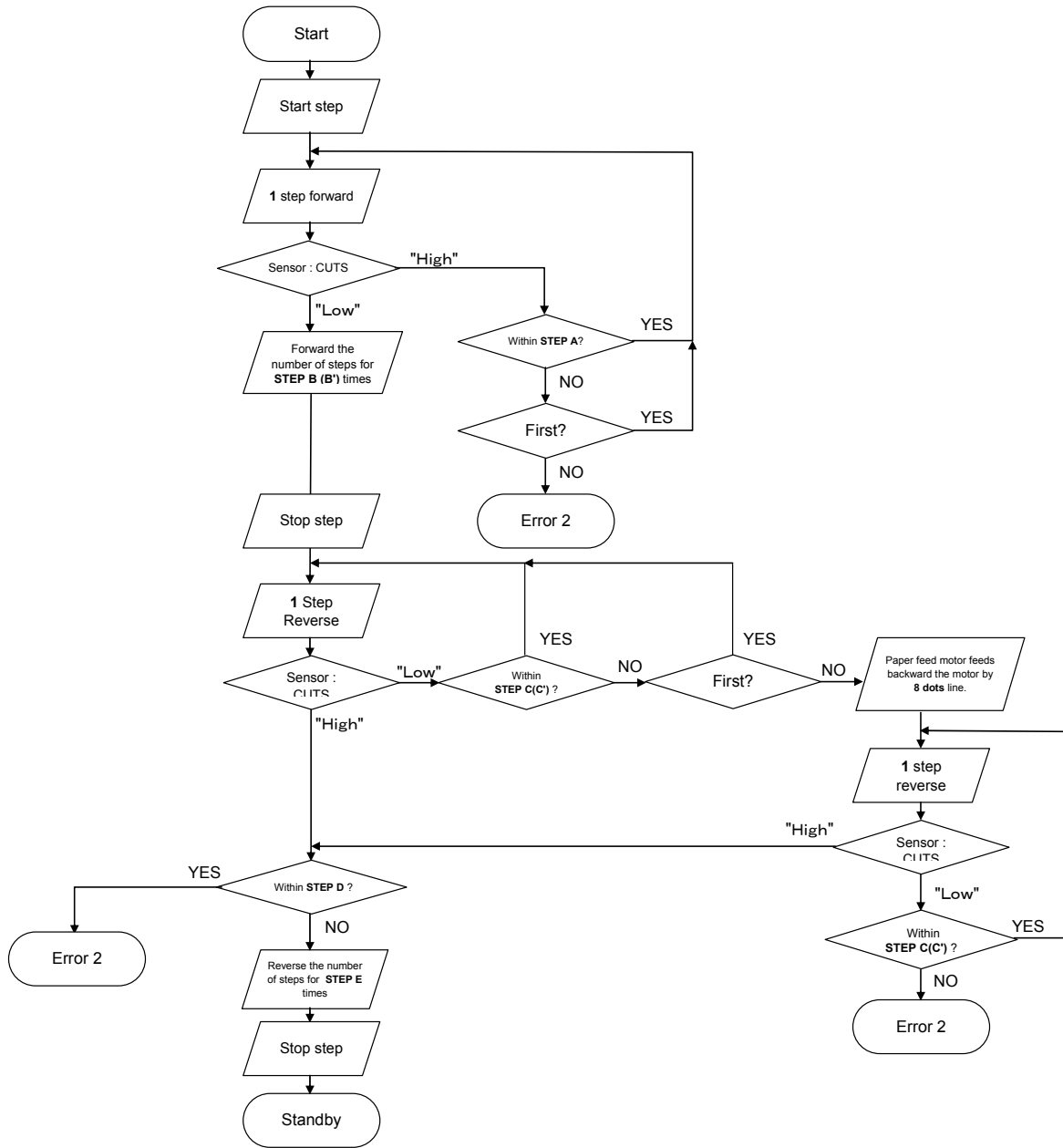

Figure 5-4 Autocutter Flow Chart : Initializing

(2) Cut performance

The flow chart of cut performance is shown in Figure 5-5.



Error 2 : It is possible that the cutter error is occurred. Refer to Chapter 8 "INSTALLING/UNINSTALLING THE THERMAL PAPER" for releasing method when the cutter error is occurred.

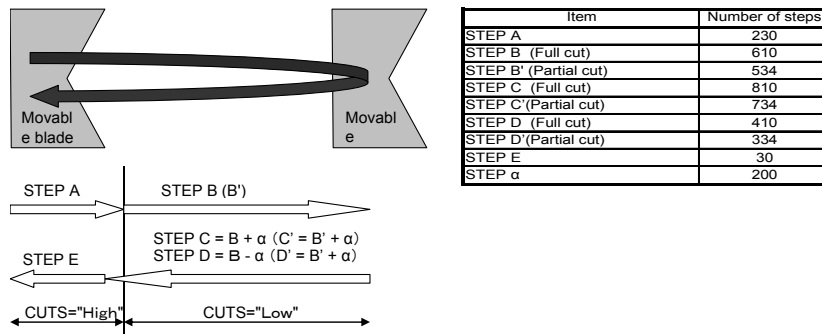

Figure 5-5 Autocutter Flow Chart : Cut Performance

5.2.3 Precautions for Using the Autocutter

- Figure 5-6 shows how to make the most efficient use of the thermal paper that margin from print area to cut area, printing “Print B” after next “Print A” is printed and cut. The distance of the cut position and the heat elements at the thermal head is 9mm approx. Do not print over the cut position. If “Print A” and “Print B” are printed as continuous pattern, its cutting operation which pauses printing during cutting the thermal paper causes a little gap between “Print A” and “Print B”.
- Remove the thermal paper which is cut with the full cut, then perform the next printing or cutting. If the printer performs the next printing or cutting without removing the thermal paper, it may cause of the paper jam or cut failure depending on the mounting position. Verify the performance with your actual device.
- The printer has been left for long period of time after cutting the thermal paper, may occur the paper jam. To prevent this case, printing or feeding 2mm or longer after cutting.
- Do not feed paper backwards after cutting with the partial cut. The part of the partial cut (tab left at the center) may be cut off.

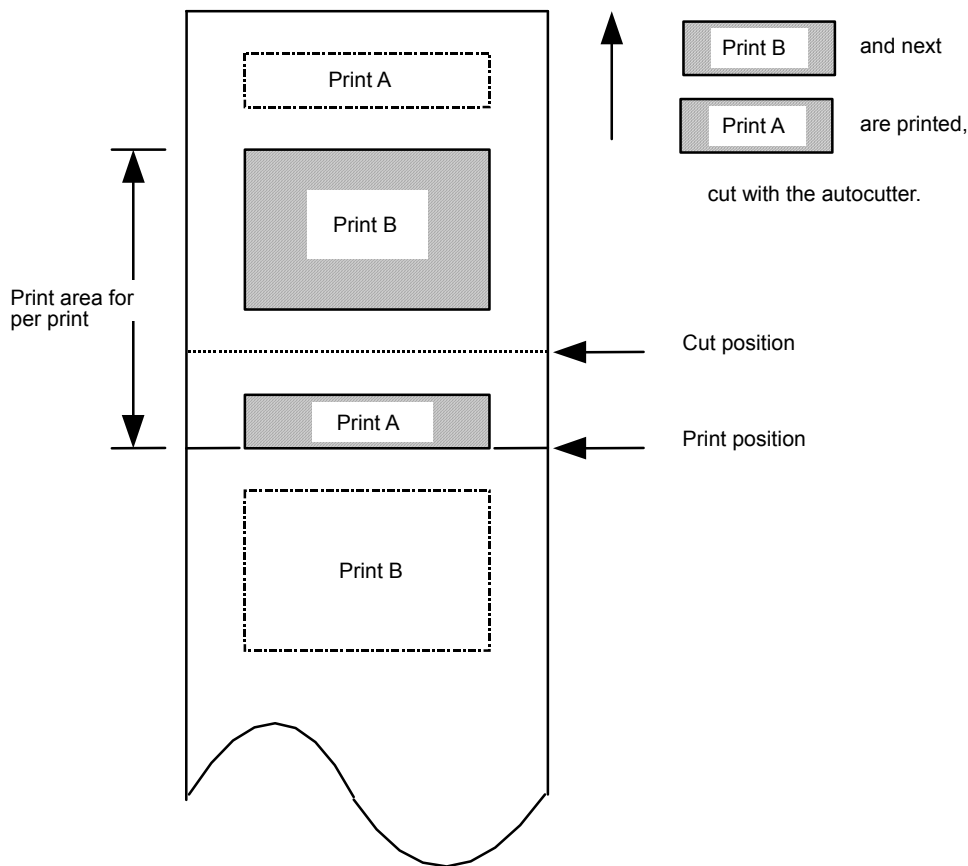
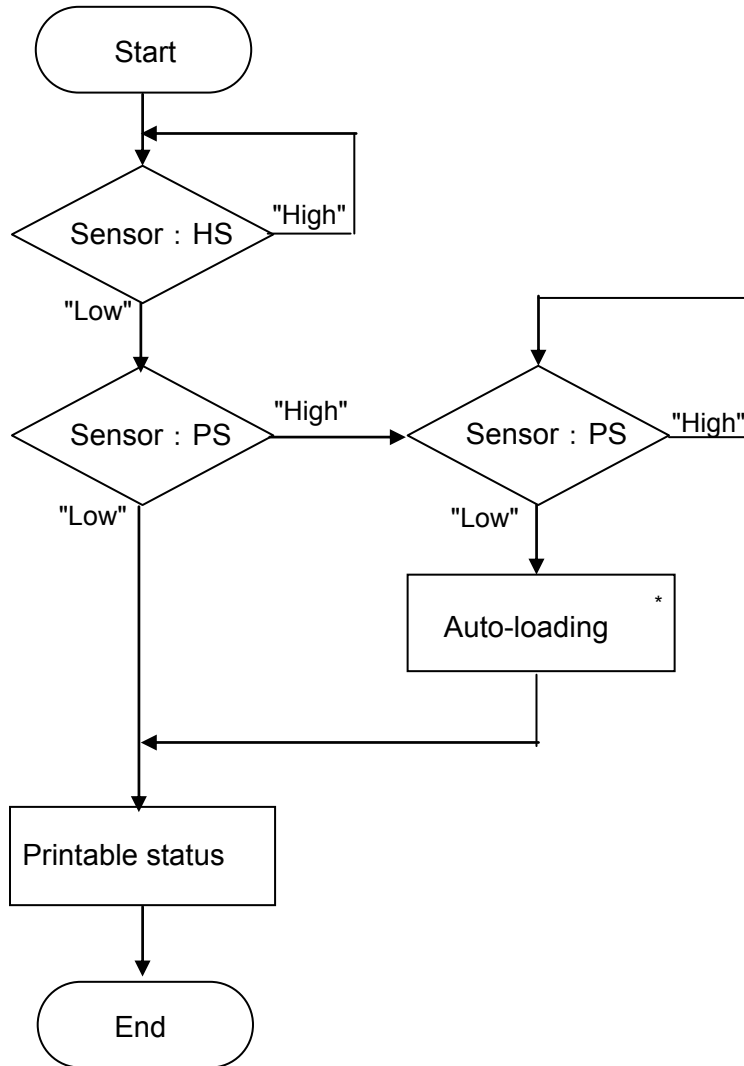

Figure 5-6 Effective Use of the Cutting Thermal Paper

5.3 AUTO-LOADING METHOD FOR THE THERMAL PAPER

It is possible auto-loading the thermal paper with out-of-paper sensor, described Chapter 3. Control the auto-loading follow the flow chart in Figure 5-7.

Procedures for installing the thermal paper by the auto-loading, refer to Chapter 8 “Procedures for Installing the Thermal Paper”.



*: Drive the printer drive motor normal rotation.

The auto-loading length is set arbitrarily.

The distance of cutting position between the heat elements and the autocutter is 9mm approx.

The motor drive pulse rate while auto-loading, it is different according to the length of the auto-loading performed.

The length of the auto-loading performed 300mm or shorter, the motor is driven by the motor drive pulse rate at 320pps regardless of the motor drive voltage.

The length of the auto-loading performed longer than 300mm, the motor is driven by the motor drive pulse rate at 320pps until the auto-loading length is 300mm.

If the length of the auto-loading performed longer than 300mm, the motor is driven by the maximum motor drive pulse rate at P_M that calculated by the motor drive voltage.

It needs few seconds, the thermal paper is fed by the platen roller after passing the out-of-paper sensor.

This time is set arbitrarily.

The distance of the thermal paper between the out-of-paper sensor and the heat elements is 8mm approx.

Figure 5-7 Flow Chart for Auto-loading the Thermal Paper

CHAPTER 6 OUTER CASE DESIGN GUIDE

6.1 MOUNTING POSITION

Figure 6-1 shows the possible mounting position (θ). This printer is able to be mounted at an angle of -45° to 225° (shaded area).

Remove the thermal paper which cut with the full cut, then perform the next printing or cutting.
If the printer performs the next printing or cutting without removing the thermal paper, it may cause the paper jam or cut failure depending on the mounting position. Verify the performance with your actual device.

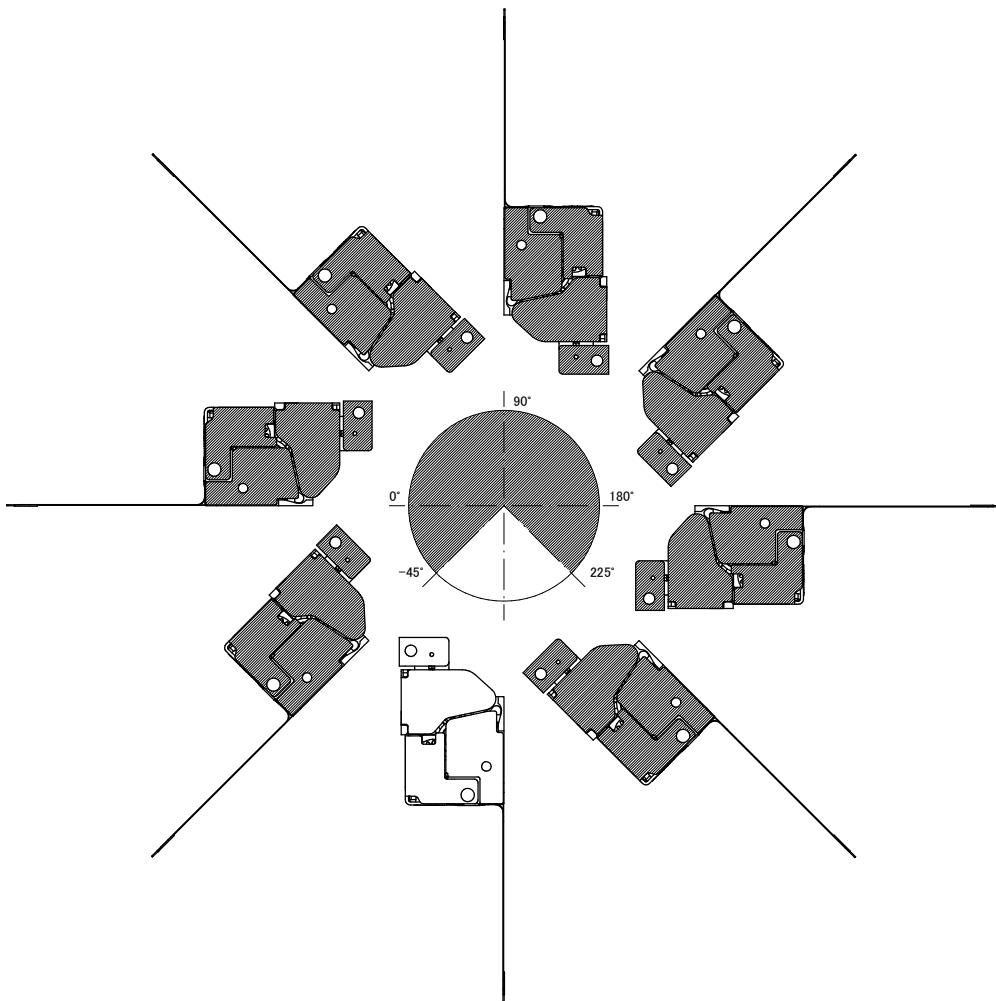

*: The printer is able to be mounted the position (θ) at shaded area. Refer to Table 6-2 for the details.

Figure 6-1 Mounting Position

Figure 6-3, Figure 6-4 and Figure 6-5 show samples for positioning and securing the printer main body.

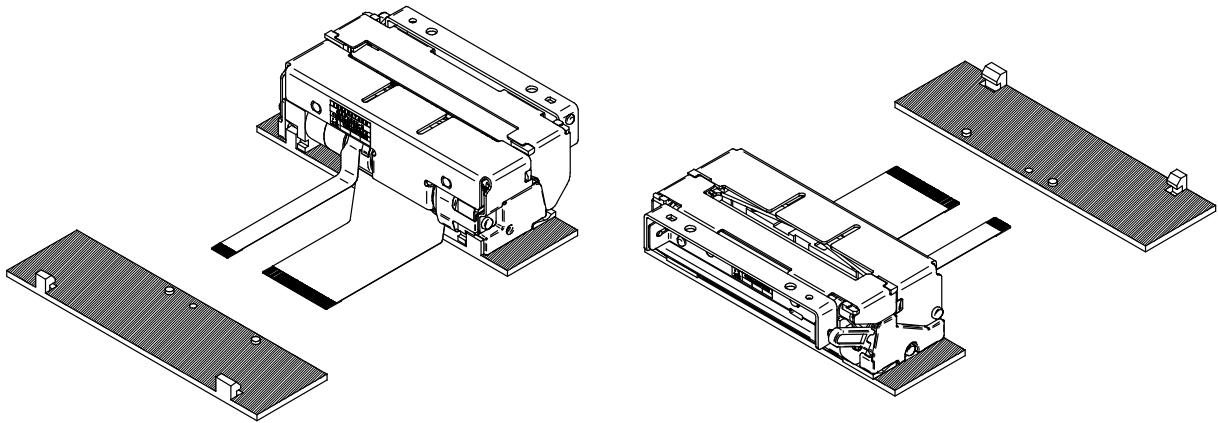

**Figure 6-3 Sample for Positioning and Securing the Printer Main Body (1)
(Fixed by the Mounting Part a, b and b')**

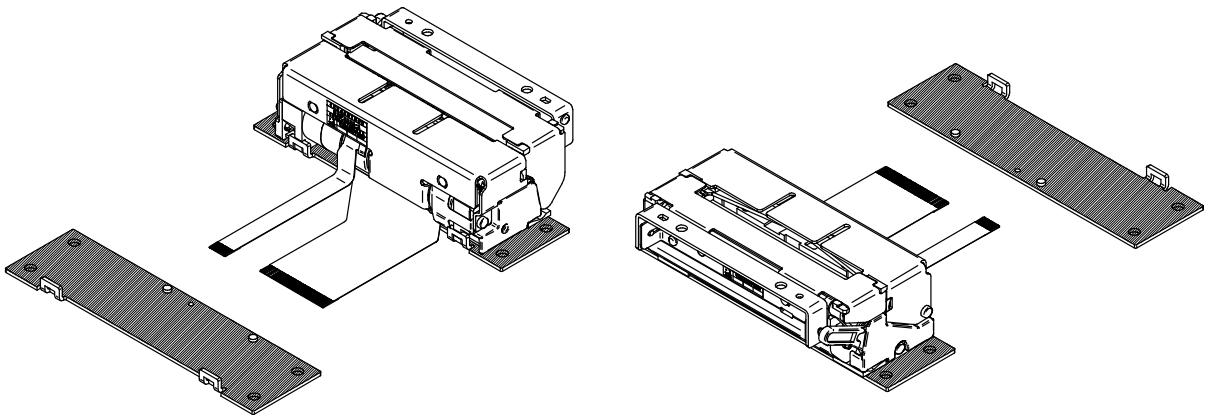

**Figure 6-4 Sample for Positioning and Securing the Printer Main Body (2)
(Fixed by the Mounting Part a, c and c')**

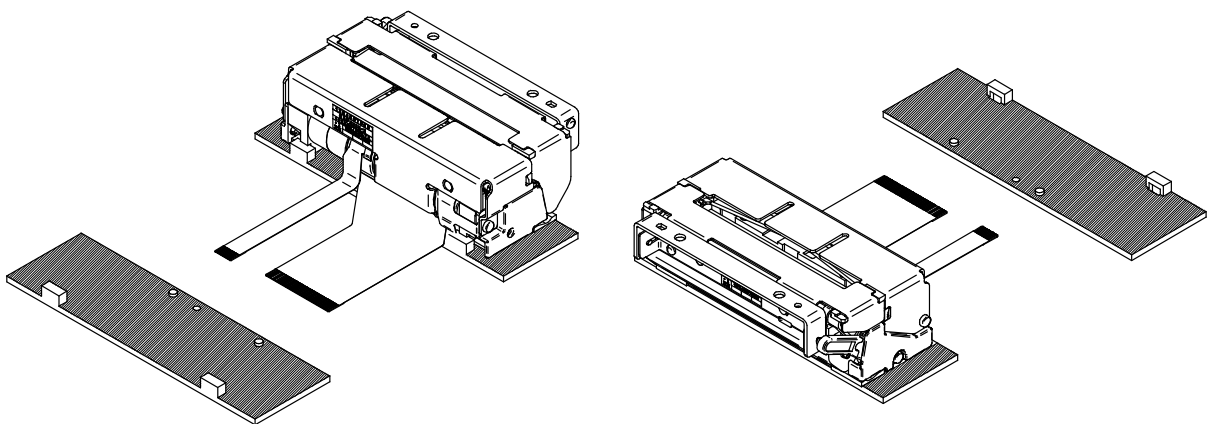

**Figure 6-5 Sample for Positioning and Securing the Printer Main Body (3)
(Fixed by the Mounting Part a, c and c')**

6.2.2 Recommended Screws

The recommended mounting screw is as follows:

- (1) JIS B1111 : M2.0 cross-recessed pan head machine screw
- (2) Tapping screw for resin : 2.0 cross-recessed pan head machine screw

6.2.3 Precautions for Securing the Printer Main Body

- Prevent from excessive stress, deformation, and torsion for securing the printer, otherwise poor printing quality, paper skew, paper jam, and noise during printing may be caused.
- The printer main body to be mounted on a flat surface and prevent from vibration.
- The strength of the fixing hook, verify with your actual device.
- Pay attention not to damage on the FPC when securing the printer main body.

6.3 SECURING THE PLATEN BLOCK

6.3.1 How to Mount the Platen Block

Figure 6-6 shows an engagement position of the printer main body and the platen block when setting or releasing the platen block mounted on the outer case, and the rotation center area for the platen block rotation system of the door (shaded area).

- The holes #3 and #4 must be used for positioning the platen block. Design the bosses for the positioning holes #3 and #4 on the outer case. The height of the bosses must be 1.5mm (Max.)
- Secure the platen block using the screw holes d and e.

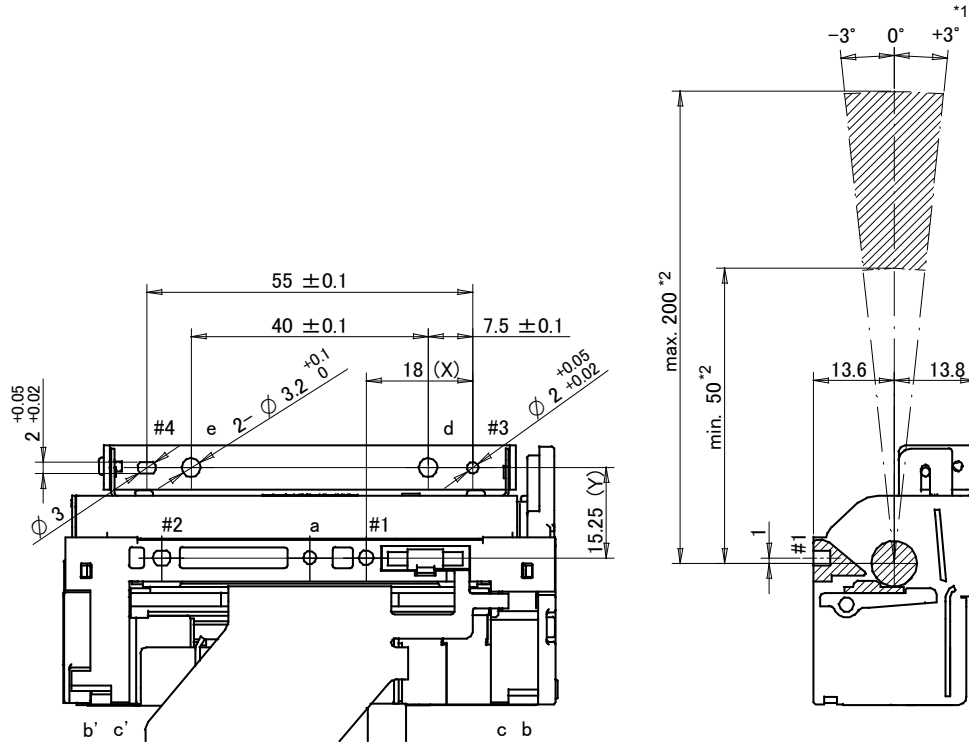

Unit : mm
General tolerance for dimensions : ± 0.3

*1: The area of the possible mounting angle (θ_z) is different according to the mounting position and distance. Refer to Table 6-2 for the details.

*2: The area of the possible mounting distance (L_z) is different according to the mounting position and angle. Refer to Table 6-2 for the details.

Figure 6-6 Dimensions for Positioning and Securing the Platen Block

Table 6-1 Allowable Dimensions

Allowable X dimension	Allowable Y dimension
18 ± 0.1	15.25 ± 0.2

Table 6-2 The Rotation Center Area for the Platen Block Rotation System of the Door

Mounting position (°)	Angle (°)	Distance (mm)					
		200≥L _Y ≥175	175>L _Y ≥150	150>L _Y ≥125	125>L _Y ≥100	100>L _Y ≥75	75>L _Y ≥50
-45°>θ≥0°	-3°≤θZ<0°	○	○	○	○	○	○
	0°	○	○	○	○	○	○
	0°<θZ≤3°	○	○	○	○	○	○
0°>θ≥45°	-3°≤θZ<0°	○	○	○	○	○	○
	0°	○	○	○	○	○	○
	0°<θZ≤3°	○	○	○	○	○	○
45°>θ≥90°	-3°≤θZ<0°	○	○	○	○	○	○
	0°	○	○	○	○	○	○
	0°<θZ≤3°	○	○	○	○	×	×
90°>θ≥135°	-3°≤θZ<0°	○	○	○	○	○	×
	0°	○	○	○	○	×	×
	0°<θZ≤3°	×	×	×	×	×	×
135°>θ≥180°	-3°≤θZ<0°	○	○	○	○	○	×
	0°	○	○	○	○	×	×
	0°<θZ≤3°	×	×	×	×	×	×
180°>θ≥225°	-3°≤θZ<0°	○	○	○	○	○	×
	0°	○	○	○	○	×	×
	0°<θZ≤3°	×	×	×	×	×	×

6.3.2 Recommended Screw

The recommended mounting screw is as follows:

- (1) JIS B1111 : M3.0 cross-recessed pan head machine screw
- (2) Tapping screw for resin : 3.0 cross-recessed pan head machine screw

6.3.3 Precautions for Securing the Platen Block

- Design the mounting position of the platen block that X and Y dimensions as shown in Figure 6-6 are within the allowable dimensions as shown in Table 6-1.
- Design the positioning hole #3-#4 of the platen block and the positioning hole #1-#2 of the printer main body that the parallelism are 0.2 or less.
- Design the platen block mounting surface to be parallel to the printer main body mounting surface :
The parallelism of the cross direction is 0.2 or less.
The parallelism of the width direction is $0 \pm 2^\circ$ or less.
- Design the rotation system of the door so that the center of the rotation is in the shaded area as shown in Figure 6-6. The platen block of the printer that structure is fluctuation of the cross direction, to keep the constant tangency angle between the movable blade and the fixed blade. According to the mounting position, it may interfere when the platen block is setting/releasing. Check the rotation center area of the rotation system of the door by Table 6-2. Verify the performance with your actual device.
- Design the rotation axis for the rotation system of the door, the positioning hole #1-#2 and the mounting surface of the printer main body that the parallelism are 0.2 or less.
- It is recommended that the rotation system of the door is guided by part of the outer case when the platen block is set into the printer main body. If the rotation fulcrum of the rotation system of the door is configured to the mounting component of the printer main body, could design with high accuracy.
- Prevent from excessive stress, deformation, and torsion for securing the platen block. It may cause of the print defect, the paper skew, the paper jam, the noise, the cut failure and the damage of the cutter blade.
- Design the rotation system of the door and the outer case strong enough to keep the allowable dimensions because stress is applied to them when setting and releasing the platen block. The rotation center for the rotation system of the door should be designed to fit the rotational shaft into the shaft hole so that the platen block should be stable when it is in the close state.
- If the printer main body and the rotation system of the door are not placed in proper position, the print defect, the paper skew, the paper jam, the noise, the cut failure and the damage of the cutter blade may occur.
- Design the outer case for the rotation system of the door that holds the platen block must be set by pushing the center of the platen block. If only one end of the platen block is set, the print defect, the paper jam, the cut failure and the damage of the cutter blade may occur. Verify the performance with your actual device. In order to be pushed the center of the platen block to set it, put an indication to do so.
- If designing the outer case with a structure to bring the platen block up automatically using a spring property after released, make sure not to apply more than enough force to bring the platen block up. If designing a structure that the only one side of the outer case is brought up, the position relation between the printer main body with the movable blade unit and the platen block with the fixed blade unit will be improperly and will result in the print defect or the cut failure. Verify the performance with your actual device.

6.4 CONNECT TO THE FRAME GROUND (FG)

To prevent the thermal head from being damaged by static electricity, it is recommended that the printer main body and the platen block are connected to frame ground (FG) of the outer case. Verify the performance with your actual device.

6.4.1 How to Connect to the Frame Ground (FG)

- Connect the printer main body to the Frame Ground (FG) of the outer case with the printer connecting terminals No.44 and 45 shown in Chapter 4, through the Frame Ground (FG) of the circuit board.
When the printer main body is connected, make the shortest possible position of the printer connecting terminals and the Frame Ground (FG) of the outer case. And those are not effect to the control signal.
- Connect the platen block to the mounting hole d or e at the Frame Ground (FG) of the outer case with the metal screw (screw with nickel coating and star washer).
- All Frame Ground (FG) must be same electrical potentials.
- Connect the Signal Ground (SG) to the Frame Ground (FG) through approximately 1 MΩ resistance.

6.5 DESIGN THE PLATEN RELEASE LEVER

Figure 6-7 shows working area of the platen release lever and Figure 6-8 shows external dimensions of the platen release lever.

When designing the button or the lever that will operate simultaneously with the platen release lever, follow the precautions below.

- Design the button or the lever and its motion so that the platen release lever is pushed to an angle of 35 degrees of the released position. Set the stopper to prevent the damage of the lever when exceeding force is applied to the platen release lever.
- Design the button or the lever so that no load is constantly applied to it while the platen block is set.

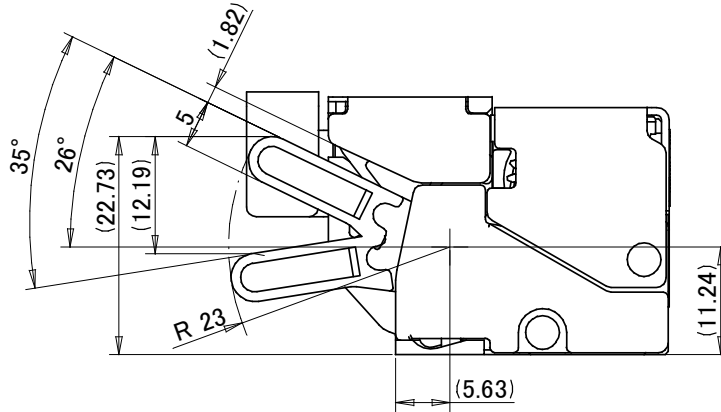

Unit : mm
General tolerance for dimensions : ± 0.5

Figure 6-7 Working Area of the Platen Release Lever

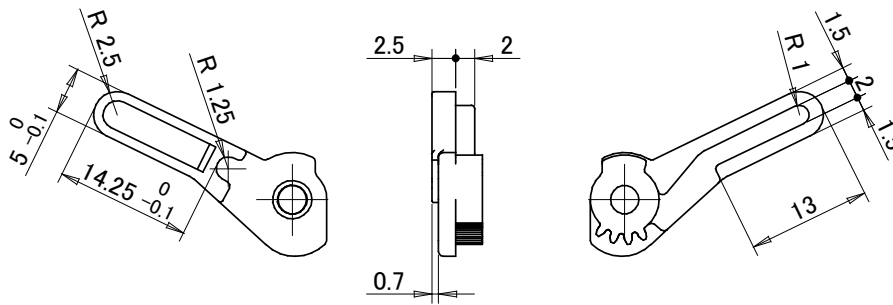

Unit : mm
General tolerance for dimensions : ± 0.1

Figure 6-8 External Dimensions of the Platen Release Lever

Figure 6-9 shows design example of the external lever for the platen release lever.

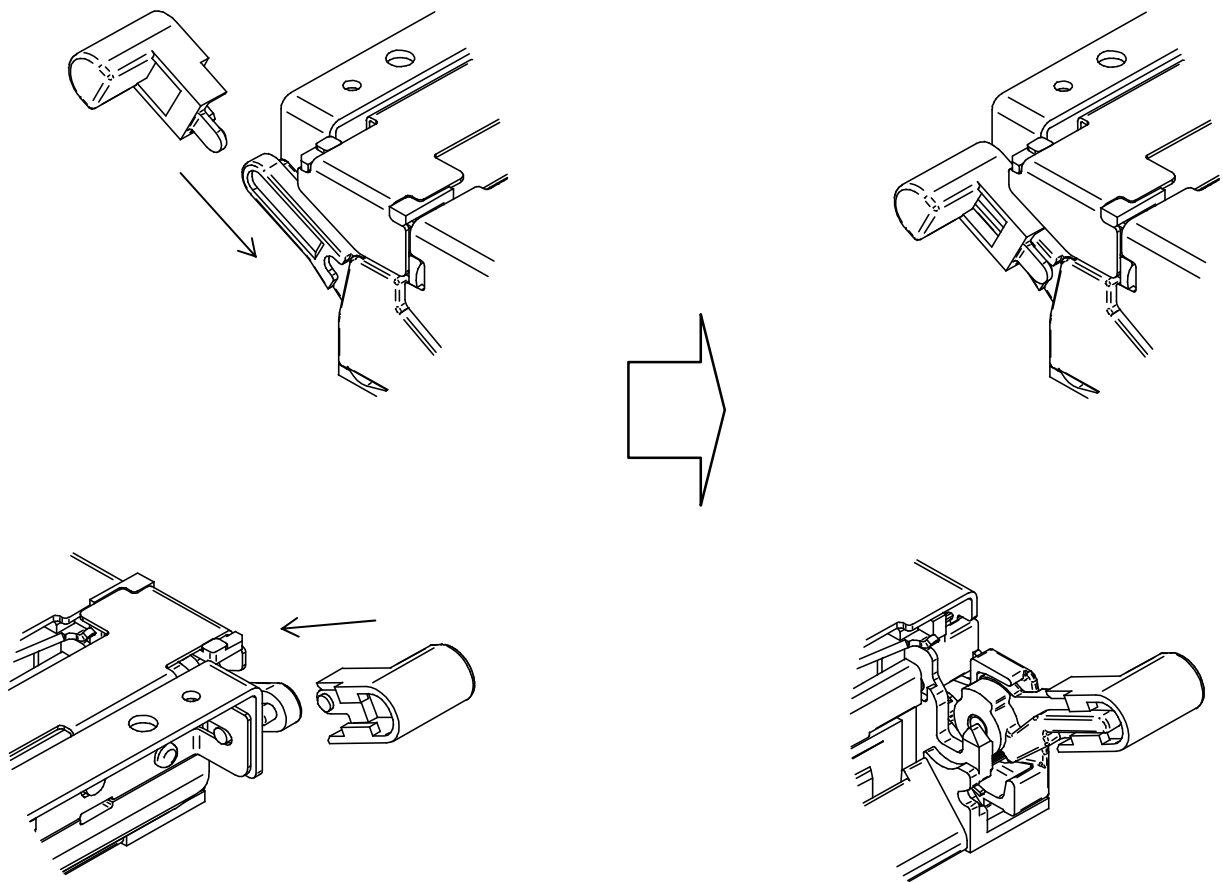

Figure 6-9 Design Example of the External Lever

6.6 LAYOUT OF THE PRINTER MECHANISM AND THE THERMAL PAPER

The printer can be laid out as follows.

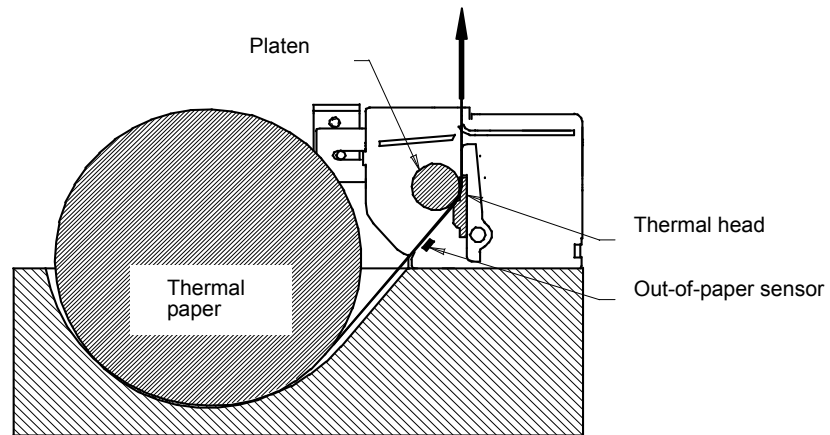

Figure 6-10 Recommended Layout between the Printer Mechanism and the Thermal Paper

*: The thermal paper feeding distance between the out-of-paper sensor and the heat element is approximately 8mm.

6.7 WHERE TO MOUNT THE PAPER HOLDER

When designing the layout of the paper holder, note the followings. The recommended configuration of the paper holder is shown in Figure 6-11.

- Keep the thermal paper will be straight to the paper inlet port without any horizontal shifting and so that the center axis of the paper roll will be parallel to the printer when using paper roll.
- Design the paper holder so that the paper feed load should be 0.49N (50gf) or less. Be aware that the printing problem and paper feed problem may occur in the following case even if it is below 0.49N. Design the paper holder so as not to make these conditions and verify the performance with your actual device.

ex)

In case that the paper roll wobbles in the paper holder.

In case that tension of the thermal paper between the paper roll and the printer changes rapidly.

In addition, do not use following types of thermal paper:

Expanded paper roll

Deformed paper roll

Roll core is sticking out.

Width of the paper roll is out of spec

- When the thermal paper feeds backwards, design the space for the thermal paper returns to the paper holder side smoothly. Otherwise the backward feed may cause paper skew and jam. Do not feed the thermal paper backwards no more than 9mm. However, the thermal paper is fed backwards no more than 7mm after cutting end. If the thermal paper is out of the holding status with the thermal head and the platen, the printer cannot feed.

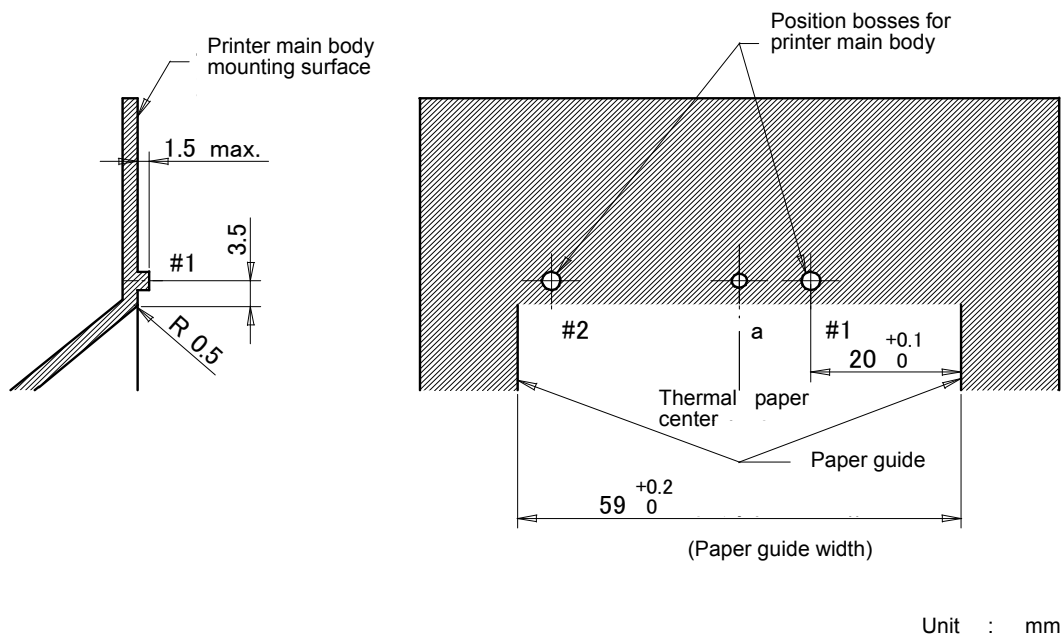

Figure 6-11 Recommended Paper Holder Dimensions

6.8 DESIGN THE PAPER EXIT

6.8.1 Design the Shape of the Paper Exit

When designing the paper exit, note the followings.

- Design the shape of the paper exit so that stress is not applied to the thermal paper comes out.
- Design the paper exit of the printer main body and the platen block as shown in Figure 6-12a and Figure 6-12b. The paper exit design should not interfere with the thermal paper coming out. Design the paper exit not to change the thermal paper coming out direction and not interfere with paper feeding. Verify the performance with your actual device, when the thermal paper direction is changed.
- Design the upper surface of the printer main body, to keep the specified space shown in the Figure 6-12a. Otherwise the cut failure may occur.
- Design the paper exit with the dimensions shown in the Figure 6-12b, to prevent the outer case of the platen block side (paper exit) from touching the movable blade during cutting.
- Design the paper exit to prevent from inserting a finger.
- Design the through paper side, there are not projection, scratch and burr. It may occur the paper jam and scratch on the thermal head.

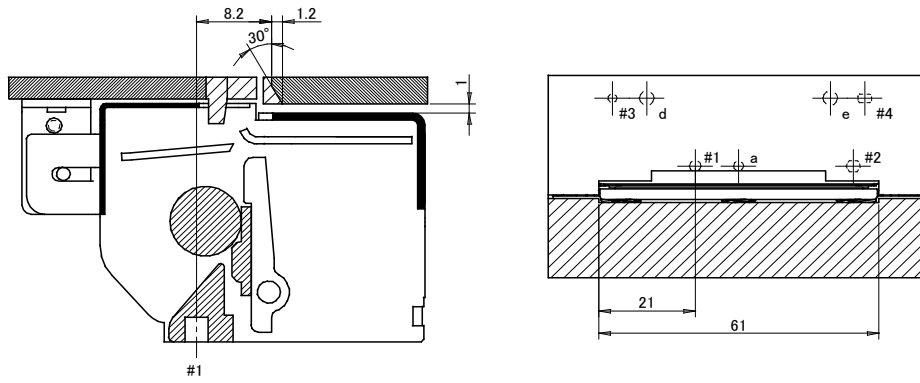

Unit : mm
 General tolerance for dimensions : ± 0.1
 General tolerance for angle : $\pm 1^\circ$

Figure 6-12a Recommended Sample of the Paper Exit (Printer main body side)

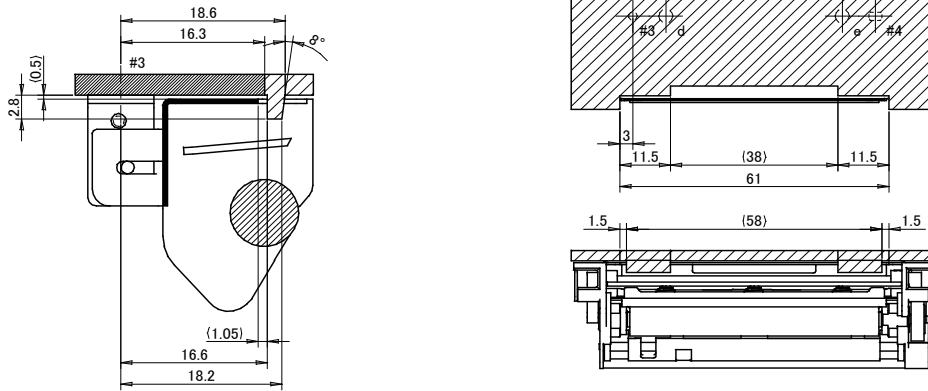

Unit : mm
 General tolerance for dimensions : ± 0.1
 General tolerance for angle : $\pm 1^\circ$

Figure 6-12b Recommended Sample of the Paper Exit (Platen block side)

6.9 PRECAUTIONS FOR DESIGNING THE OUTER CASE

- In this printer, the platen block is removable from a printer main body so that the thermal paper can be set easily. Therefore, when the platen block is in open state, the fixed cutter blade becomes exposed. To prevent the users from injuring himself/herself by touching the cutter blades while the autocutter is in operation and replacing the thermal paper, design a structure such as a shutter in the outer case or place warning labels to warn users to ensure safe operation.
- The thermal paper with a small winding diameter may cause the paper jam in the printer main body and a gap between the printer and the outer case. If using such a thermal paper with the small diameter, verify the performance with your actual device.
- Design the outer case to ensure enough space to allow the users to handle the platen release lever easily with fingers.
See Chapter 8 “PROCEDURES for INSTALLING/UNINSTALLING THERMAL PAPER” for specific procedures. Also, see 6.5 “DESIGN THE PLATEN RELEASE LEVER” for its motion.
- Design the outer case will not apply any load from outside to the printer main body and the platen block except the operation part. The load may cause the print defect, the paper jam, the cut failure and the damage of the printer. Secure 1.0mm (min.) space between the printer main body and platen block and the outer case.
- Paper powders can be caused while the autocutter is working. Be sure to design an outer case not to have the paper powders piled up on the control board and the power supply as this may cause short circuit failure.
- Temperature of the thermal head and its peripherals rises very high during and immediately after printing. Be sure to design the outer case to prevent users from burn injuries by touching them. Place warning labels to warn users to ensure safe operation. As for thermal head cleaning, warn users to allow the thermal head to cool before cleaning. In order to allow cooling, secure clearance between the thermal head and the outer case when designing the outer case.
- Temperature of the motor and its peripherals rises very high during and immediately after printing. Be sure to design the outer case to prevent users from burn injuries by touching them. Place warning labels to warn users to ensure safe operation. In order to allow cooling, secure clearance between the motor and the outer case when designing the outer case.

CHAPTER 7

EXTERNAL DIMENSIONS

Figure 7-1 shows external dimensions of CAPD245.

CHAPTER 8

HANDLING METHOD

8.1 INSTALLING/UNINSTALLING THE THERMAL PAPER

8.1.1 Procedures for Installing the Thermal Paper

(1) Procedure for installing the thermal paper by the easy operation (setting and releasing the platen block)

- Push the platen release lever in the direction of the arrow in the Figure 8-1a.
- Pull up the platen block after making sure that the platen block is released from the printer main body. (Open state)
- Set the thermal paper straight to the printer and leave at least 5cm of the thermal paper come out from the printer mechanism in the Figure 8-1b.
- Set the platen block in the Figure 8-1c after making sure that the thermal paper is set straight. (Close state)

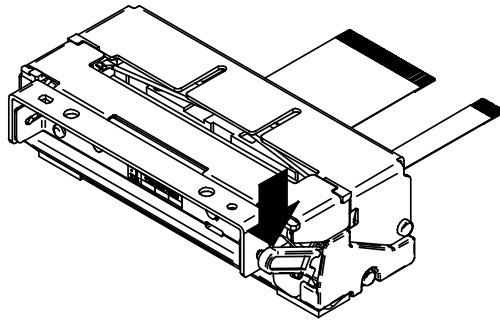

Figure 8-1a Installing the Thermal Paper by the Easy Operation

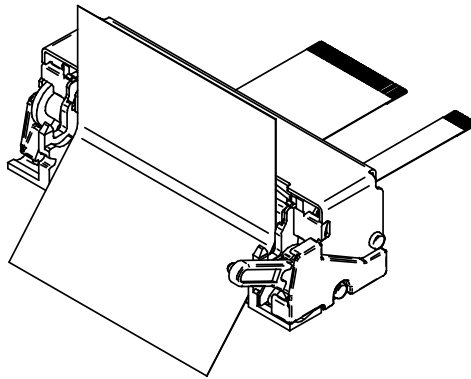

Figure 8-1b Installing the Thermal Paper by the Easy Operation

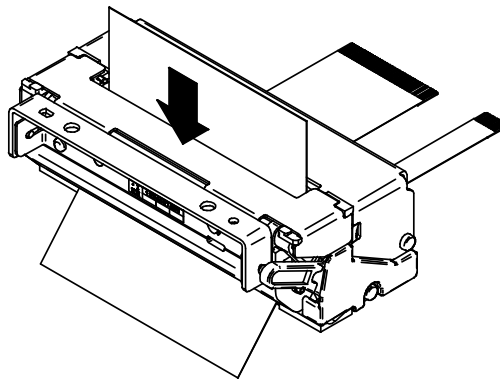

Figure 8-1c Installing the Thermal Paper by the Easy Operation

(2) Procedure for installing the thermal paper by the auto-loading (the platen block in the close state)

- Set the platen block in the close state.
- Well-cut the thermal paper edge with scissors and cutter knife. Cutting the thermal paper edge perpendicular to paper feed direction, shown in Figure 8-2.
- Load the thermal paper from the paper inlet to run into the edge, shown in Figure 8-3.
- Feed the thermal paper while inserting the thermal paper. Refer to Chapter 5 “Auto-loading Method for the Thermal Paper” for control method.

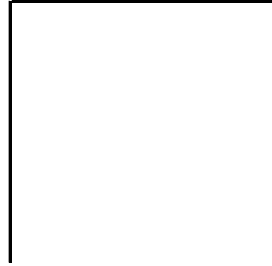

Figure 8-2 Shape of the Thermal Paper Edge

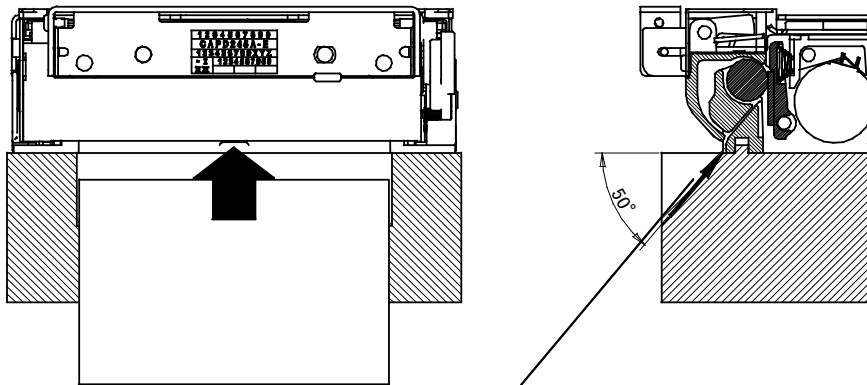

Figure 8-3 Installing the Thermal Paper by the Auto-loading

8.1.2 Procedures for Uninstalling the Thermal Paper

(1) Procedures for uninstalling the thermal paper by paper feed

It is possible uninstalling the thermal paper without releasing the platen block.

- Cut the thermal paper near the paper inlet.
- Feed paper until all thermal paper is discharged.

(2) Procedures for uninstalling the thermal paper by releasing the platen block

- Push the platen release lever in the direction of the arrow in the Figure 8-1a.
- Pull up the platen block after making sure that the platen block is released from the printer main body.
- Remove the thermal paper.

8.1.3 Procedures for Removing the Paper Jam

(1) Push the platen release lever in the direction of the arrow in the Figure 8-1a.

(2) Pull up the platen block after making sure that the platen block is released from the printer main body.

(3) Remove the thermal paper.

8.1.4 Procedures for Releasing when the Movable Blade is Stopped

When the movable blade is stopped during cutting performance, release the movable blade the following procedures and back to the home position.

(1) Push the platen release lever in the direction of the arrow in the Figure 8-1a.

(2) If the movable blade cannot release at once, repeat the motion of the above. And so the movable blade is returned to the home position.

(3) Release the platen block in the same way as "Procedures for Removing the Paper Jam". And remove the cause of stopping the movable blade.

8.1.5 Precautions for Installing/Uninstalling the Thermal Paper

- When setting the platen block, the reduction gear may interfere with the platen gear and may cause the platen block to not be set. In such a case, release the platen block and set it again.
- If the thermal head is remained in contact with the platen without the thermal paper for a long time, the platen and the thermal head may be stuck together and cause the auto-loading difficulty. If facing this problem, release the platen block and set it back again before starting printing.
- If the thermal paper is skewed, feed the thermal paper until the thermal paper becomes straight, or release the platen block and install the thermal paper again.
- Release the platen block to remove jamming paper. Do not pull the thermal paper by force because severe damages may occur.
- The thermal paper is not elastic at high temperature or high humidity environment. It may cause the thermal paper insertability by the auto-loading is decreased and the paper jam. Verify the performance at the usage environment.
- The thermal paper with a small winding diameter and strong curl may cause the thermal paper insertability by the auto-loading is decreased and the paper jam.

8.2 CLEANING THE THERMAL HEAD

If the surface of the thermal head exposed to dirt, ensure to clean the thermal head to avoid a print defect.

8.2.1 Procedures for Cleaning the Thermal Head

- (1) Turn the power off.
- (2) Push the platen release lever to the direction of the arrow in the Figure 8-1a.
- (3) Pull up the platen block after making sure that the platen block is released from the printer main body.
- (4) Clean the heat element shown in Figure 8-4 using a cotton swab dipped in ethyl alcohol or isopropyl alcohol.
- (5) Set the platen block after the alcohol has dried completely.

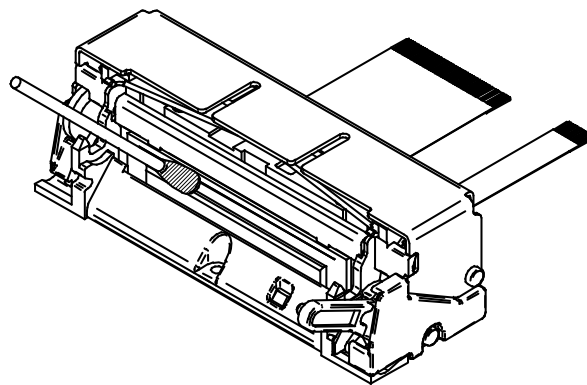

Figure 8-4 Cleaning Position of the Thermal Head

8.2.2 Precautions for Cleaning the Thermal Head

- Do not clean the thermal head immediately after printing because the temperature of the thermal head and its peripherals rises very high during and immediately after printing.
- Clean the thermal head with the platen block released.
- Do not use sandpaper, a cutter knife and etc. for cleaning. They will damage the heat element.